

G 31239



1/2025

**VA** VERLAG  
Cologne/Germany

# 挤出和回收 亚洲

## EXTRUSION & RECYCLING ASIA

# Guill

WORLD LEADER IN EXTRUSION TOOLING

6 Layer Tubing Die

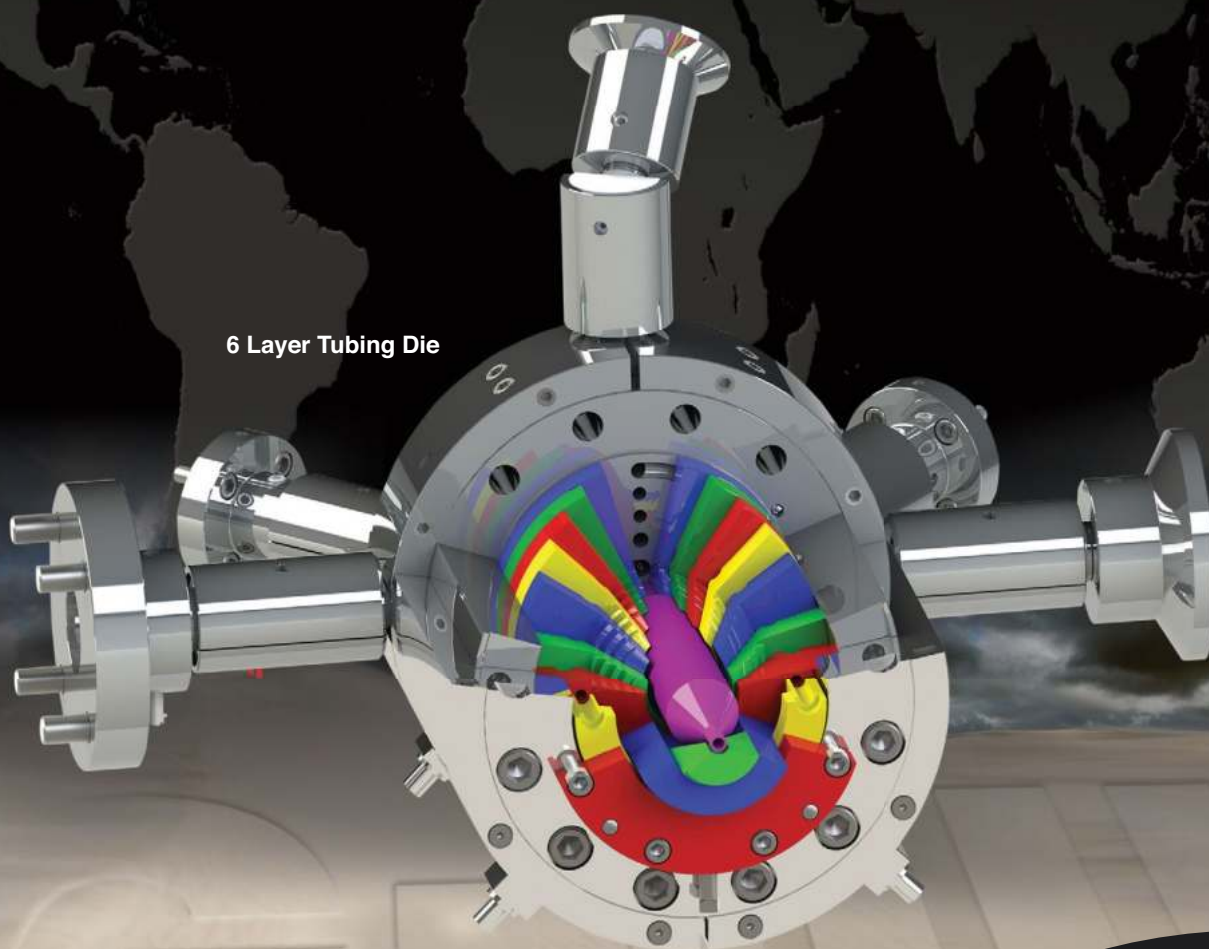

[www.guill.com](http://www.guill.com)

**GUILL**  
Now Offers  
Basket Dies

# SMART EXTRUSION

The only website collecting information about smart technologies of extrusion

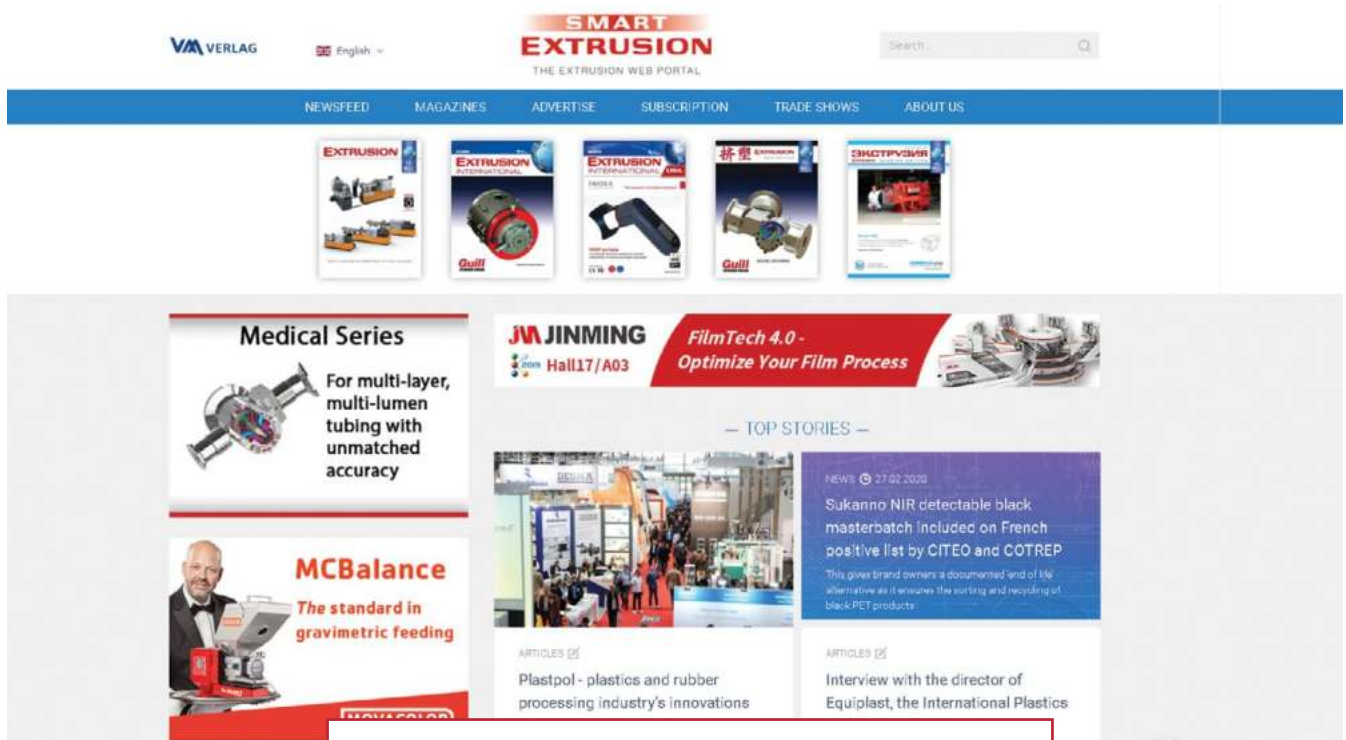

## A SPECIALIZED WEB PORTAL

- ▶ News about relevant products and events
- ▶ Video clips demonstrating smart equipment in live action
- ▶ Detailed reviews of various smart technologies
- ▶ Latest magazines available for reading and downloading
- ▶ Case studies from processors
- ▶ Weekly e-mail newsletters
- ▶ English, German, and Chinese

**38 400 + average monthly visits**

Geographic distribution of **Smart\_Extrusion** readers, %

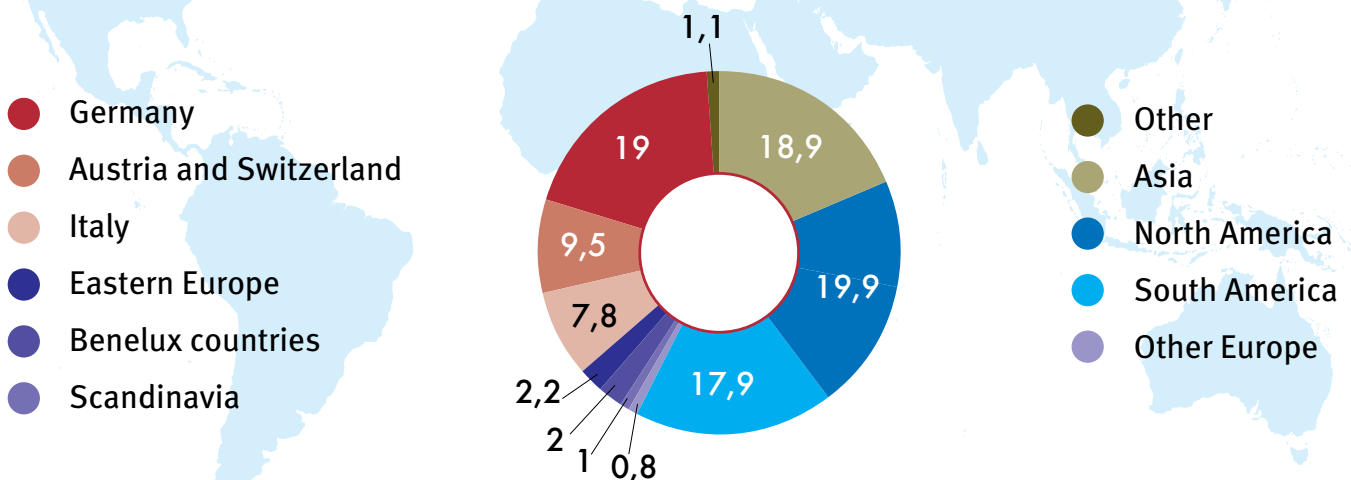

[www.smart-extrusion.com](http://www.smart-extrusion.com)

# 内容/ CONTENT

## 标题 / Front page:

Guill Tool & Extrusion Co., Inc.  
www.guill.com

## 本期杂志中的公司目录 / 敬请垂询

Firms in this issue / Imprint 4

## 行业新闻 / Industry News 6

K 展年启动 — 杜塞尔多夫为 K 2025 做好起跑准备

Kick-Off for the K Year – Düsseldorf  
in the Starting Blocks for K 2025 6

2024 年 swop 展会圆满落幕

swop 2024 Concludes with Success 7

宣布拓展欧洲市场

Expansion in the European Market Announced 9

亚太区新总部位于曼谷

New Head Office Asia-Pacific in Bangkok 10

在印度的地位得到加强

Position in India Strengthened 10

人员信息

Personalia 12

泰国的新工厂开业了

New Plant in Thailand Opened 14

在华扩建，沧州第二条高性能添加剂生产线开工建设

Construction of Second High Performance Additives  
Production Line in Cangzhou, China, Begun 16

推出全新转舌锁设计

New Cam- Lock Design Introduced 17

吹塑模具

Blow Molding Dies 18

扩张

Expansion 18

推出新型医用级热塑性弹性体 (TPE)

New Medical Grade Thermoplastic Elastomers  
(TPEs) Introduced 19

## 挤压工具 / Extrusion Tooling

挤压技术新发展

Extrusion Takes Some New Turns 20

## 管材挤出 / Pipe Extrusion

将PO管材生产中的能源和原材料成本降至最低

Minimize Energy and Raw Material Costs  
in PO Pipe Production 24

## 回收、薄膜挤出 / Recycling, Film Extrusion

合作 – 生产包含再生材料的拉伸膜

Collaboration – Production of Stretch Film  
that Incorporates Recycled Content 26

## 回收 – 案例研究 / Recycling – Case Study

采用回收技术的可持续包装

Sustainable Packaging with Recycling Technology 28

## 加工 / Processing

全球化思维，本地化行动

Thinking Globally, Acting Locally 30

## 薄膜挤出，数字化 / Film Extrusion, Digitalisation

数据驱动决策的一站式解决方案

One-Stop Solution for Data-Driven Decisions 32

## 管材挤出 / Pipe Extrusion

考虑更大：一条现代化的生产大直径管材的  
生产线 聚乙烯管直径高达1600毫米

Think Big: A Modern Line for the Production  
of Large-Diameter Polyethylene Pipes up to 1600 mm 34

## 管材挤出 / Measurement Technologie – Case Study

节约管道生产的成本

Cost Savings in the Production of Pipes 36

## 2025中国国际橡塑展 / CHINAPLAS 2025

通过在挤出、印刷和纸制品加工方面的创新解决方案，  
实现可持续的软包装

Sustainable Flexible Packaging through Innovative  
Solutions in Extrusion, Printing  
and Converting 38

创新的测量技术和分选解决方案

Innovative Measuring Technology  
and Sorting Solutions 40

消费后和工业后回收的创新解决方案

Innovative Solutions for Post-Consumer  
and Post-Industrial Recycling 42

2025年Chinaplas国际橡塑展我们将展示什么？

What's up at Chinaplas 2025? 44

高效的拉伸薄膜生产线适用于各种高质量  
包装和特种薄膜应用的生产线

Highly Efficient Film Stretching Lines Packaging  
and Specialty Film Lines for a Variety of Top Quality  
Applications 46

适用于薄膜拉伸生产线的本地化、  
经济高效且可持续的服务解决方案

Local, Cost Efficient and Sustainable Service  
Solutions for Film Stretching Lines 47

VACUREMA® 系列每小时产量高达 6 吨

VACUREMA® Machines Recycle Up To 6 Tonnes  
of PET Per Hour 49

<b>ALPLA</b> .....	14
<b>BASF</b> .....	10
battenfeld-cincinnati.....	24
Brückner .....	12, 46
Brückner Servtec.....	47
<b>CHINAPLAS 2025</b> .....	38
Clariant .....	16
<b>EREMA</b> .....	49
<b>Gneuss</b> .....	26, 28, 42
Guill Tool & Engineering.....	封面 / Front Cover, 9, 17, 18, 20
<b>K 2025</b> .....	6
Koch-Technik.....	13
<b>MAAG</b> .....	30
Mauser Packaging.....	18
Messe Düsseldorf.....	6, 7
<b>PlasMec</b> .....	9
<b>Reifenhäuser</b> .....	10
<b>Sikora</b> .....	39, 40
Smart-Extrusion .....	45, Inside+Outside Back Cover
SML .....	15, 32, 44
Swop 2024.....	7
<b>Tecnomatic</b> .....	34
Teknor Apex .....	19
<b>VM Verlag</b> .....	31, Inside Front Cover
<b>Windmüller &amp; Hölscher</b> .....	38
<b>Zumbach</b> .....	11, 36

# 挤出和回收 亚洲

## EXTRUSION & RECYCLING ASIA

VM 出版社有限公司 / VM Verlag GmbH:  
Krummer Büchel 12, D-50676 Köln, Cologne, Germany

VM 出版社有限公司 / 编辑+出版  
VM Verlag GmbH – Editorial Office + Layout:  
P.O. BOX 50 18 12, D-50978 Cologne, Germany  
*Bettina Jopp-Witt M.A.*  
(Editor-in-Chief EXTRUSION, EXTRUSION International,  
EXTRUSION Asia Edition)  
T.: +49 221 546 15 39  
email: b.jopp-witt@vm-verlag.com,  
redaktion@vm-verlag.com

VM 出版社有限公司 / 广告与销售  
VM Verlag GmbH – Sales + Distribution:  
P.O. BOX 50 18 12, D-50978 Cologne, Germany  
*Dipl.-Ing. Alla Kravets (Administration)*  
T.: +49 2233 9498793  
e-mail: a.kravets@vm-verlag.com  
*Martina Lerner (Sales)*  
T.: +49 6226 97 15 15,  
e-mail: lerner-media@t-online.de  
*Tanja Bolta (Sales)*  
T.: +49 15205626122,  
e-mail: t.bolta@vm-verlag.com

第29出版年 - 出版次数: 每年2期  
29. Volume – Frequency: 2 issues a year



色母粒工會器官

全球代理 / Representatives:



JAPAN  
Tel.: +81 (3) 32732731  
extrusion@tokyopr.co.jp



CHINA & ASIA  
Tel.: +86 13602785446  
maggieliu@ringiertrade.com  
Tel.: +886-913625628  
sydneylai@ringiertrade.com  
Tel.: +852-9648-2561  
octavia@ringier.com.hk

[www.smart-extrusion.com](http://www.smart-extrusion.com)



# 28

Ester Industries 正计划安装 Gneuss OMNI 200 系统，以促进可持续的 BOPET 薄膜生产，符合印度 2025 年的回收目标和监管要求。

Ester Industries is planning to install Gneuss OMNI 200 system to boost sustainable BOPET film production, aligning with India's 2025 recycling goals and regulatory requirements.



# 30

MAAG (马格) 集团总一直在加强其在中国的本地化战略。MAAG 中国拥有 100 多名积极进取的员工，为客户提供生产、销售和各種服务。

The internationally operating MAAG Group has been stepping up its localization strategy in China. MAAG China offers its customers production, sales and various services with over 100 highly motivated employees.



# 36

“我们研究了机器运转时间、人力成本和废料成本，我们的投资回收期大约是 3 到 4 个月。”SWM 国际的生产经理 Todd Clarke 说。

“We studied machine time, manpower costs and scrap costs, and the return on our investment was about 3 to 4 months,” Todd Clarke, Production Manager at SWM International.



# 40

2025 中国国际橡塑展：SIKORA(西科拉)将在深圳为软管、管道、管材和塑料行业提供高精度的测量、控制和分选技术。

At CHINAPLAS SIKORA will present highly precise measuring, control and sorting technologies for the hose, tube, pipe and plastics industry in Shenzhen.



# 46

在深圳举行的 2025 年中国国际橡塑展上，布鲁克纳的专注点是为了在生产制造过程中使用最低单位能量和原材料消耗来提供最高效率的拉伸薄膜线。

At Chinaplas Brückner's clear focus is on the highest efficiency of film stretching lines for a manufacturing process with lowest specific energy and raw material consumption.





### Plastics Industry Fly-In

08 - 10 April 2025  
Washington, DC / USA  
<https://e.plasticsindustry.org/>

### CHINAPLAS 2025

15 - 18 April 2025  
Shenzhen / P.R. China  
[www.chinaplasonline.com](http://www.chinaplasonline.com)

### FlexForum

22 - 24 April 2025  
Orlando, FL / USA  
<https://e.plasticsindustry.org/>

### Plastasia

9 - 12 May 2025  
Bangalore / India  
[www.plastasia.in](http://www.plastasia.in)

### T-PLAS 2025

14 - 17 May 2025  
Bangkok / Thailand  
[www.tplas.com](http://www.tplas.com)

### Plastpol

20 - 23 May 2025  
Kielce / Poland  
[www.targikielce.pl](http://www.targikielce.pl)

### Greenplast

27 - 30 May 2025  
Milan / Italy  
[www.greenplast.org](http://www.greenplast.org)

### National Plastics Conference

22 - 25 September 2025  
Orlando, FL / USA  
<https://e.plasticsindustry.org/>

### K 2025

08 - 15 October 2025  
Düsseldorf / Germany  
[www.k-online.de](http://www.k-online.de)

### Vinyl Week 2025

10 - 12 December 2025  
New Orleans, LA / USA  
<https://e.plasticsindustry.org/>

### Swiss Plastics Expo

20 - 22 January 2026  
Luzern / Switzerland  
[www.swissplastics-expo.ch](http://www.swissplastics-expo.ch)



## K 展年启动 — 杜塞尔多夫为 K 2025 做好起跑准备

2025K展商数据库自1月中旬起已上线。如今已全部预订完毕，这一塑料和橡胶行业的领先展会将在展会开始前就凭借其价值链上的国际领军企业的参与以及丰富的行业知识和信息脱颖而出。

2025年10月8日至15日，杜塞尔多夫K展将再次成为全球塑料和橡胶行业的核心商业枢纽。其主题“塑料的力量！绿色 - 智能 - 负责任”凸显了行业当前的价值观和目标，并强调塑料是许多领域不可或缺的组成部分，对创新和进步贡献巨大。

尤其是在当今充满挑战的时代，K展再次证明了其作为世界领先展会的卓越相关性。这里是整个价值链汇一堂展示顶尖成果的地方，也是应对该

行业挑战的场所。没有其他活动能像杜塞尔多夫K展这样拥有如此国际化的氛围、非凡的创新力以及如此丰富多样的产品发布。K 2025 代表着跨越国界和大陆的创新解决方案和可持续发展的开放对话与交流。来自 61 个国家的参展商将参加杜塞尔多夫的K展，预计 18 个展厅将有超过 3000 家参展商。展览场地再次全部预订一空。

K 2025 的参展商数据库可在 [www.k-online.com/2410](http://www.k-online.com/2410) 访问。

在 [www.k-online.com](http://www.k-online.com)，K展 不仅在如此早期阶段就提供了关于 10 月展会的详细信息，还通过其他渠道提供了众多机会，以深入了解行业当前的发展动态，并从全球 K 展社区中获益。

## Kick-Off for the K Year – Düsseldorf in the Starting Blocks for K 2025

The K 2025 exhibitor database has been online since mid-January. Now completely booked up, this leading trade fair of the plastics and rubber industry will once again stand out with its participation of international market leaders along the value chain and industry know-how and information galore well before the start of the trade fair.

From 8 to 15 October 2025 K in Düsseldorf will again become the central business hub for the global plastics and rubber industry. It sets clear accents with its motto “The Power of Plastics! Green – Smart – Responsible”. This slogan reflects the industry’s current values and targets and emphasises that plastics are an indispensable component of



many sectors that contribute significantly to innovation and progress.

Especially in today's challenging times K once again proves its outstanding relevance as a world-leading trade fair. It is the place where the entire value chain unites to present top performances and where the challenges of this industry are addressed. No other event boasts such international flair, extraordinary innovative power and such a rich variety of product launches as does K in Düsseldorf.

K 2025 stands for the open dialogue and exchange on innovative solutions and sustainable developments that forge connections across national borders and continents. Exhibitors from 61 countries will take

part in K in Düsseldorf and more than 3,000 exhibitors are expected in the 18 exhibition halls. The fairgrounds are fully booked once again.

The exhibitor database of K 2025 can be accessed at [www.k-online.com/2410](http://www.k-online.com/2410).

At [www.k-online.com](http://www.k-online.com) K not only provides details on the event in October already at this early stage but also offers numerous opportunities via other channels to obtain in-depth information about the industry's current developments and to benefit from the global K Community.

► [www.k-online.de](http://www.k-online.de)

[www.k-online.com/2410](http://www.k-online.com/2410)



(Photo: Messe Düsseldorf/Tillmann)

## 2024 年 swop 展会圆满落幕

2024 年 11 月 20 日，上海国际包装工业展览会 (swop) 在中国上海圆满落幕，为亚洲包装行业的年度盛会画上了圆满句号。今年的展会作为年度顶级盛会，展现了全新的视野，并与市场动态需求高度契合。swop 以全球化为着眼点，已成为整个包装产业链中不可或缺的展览、交流与合作平台。

swop 2024 展会面积超过 65000 平方米，吸引了来自全球 903 家知名企业参展，其中包括来自中国、德国、西班牙、芬兰、美国等众多国家和地区的参展商。展会共迎来 33192 名来自世界各地的专业观众，为参展商和采购商提供了一个充满活力的交流空间，共同探讨全球供应链变化带来的合作机遇。

杜塞尔多夫展览 (上海) 有限公司总经理 Evian Gu 表示：“作为连接生产和消费的重要桥梁，包装行业的需求持续增长。”这一增长不仅彰显了全球贸易的活力，也反映了各行业持续推动创新、提升产品包装质量的努力。作为 interpack (国际加工与包装机械展览会) 联盟的一员，swop 得到了广泛的支持，这增强了其国际影响力和覆盖面。

雅式集团副主席 Rita Chu 表示：“swop 一直是行业热点和趋势的风向标，今年也不例外，亮点纷呈。”“可持续性”可以说是全球包装行业的共识，而“走出去”则为众多企业开辟了新的蓝海。今年，来自各行各业的 swop 参展商不仅能洞悉包装行业的最新动态和技术趋势，还能找到符合自身发展需求的理想解决方案。



### 2024 年 swop 展会亮点 — 展示前沿包装行业技术及发展趋势

- 聚焦包装设备的数字化、智能化和自动化以及新技术
- 关注包装容器和餐具生产线，展示创新技术和环保材料
- 引领包装行业的绿色革命：展示创新环保材料
- 2024 年 swop 快消品包装馆：助力品牌大放异彩

作为 swop 2024 的一大亮点，国际馆得到了“interpack 联盟”的大力支持。此次展会汇聚了众多国际知名参展商，

他们展示了来自世界各地的前沿包装解决方案，彰显了推动国际包装行业发展的新质生产力。swop 一直密切关注新兴趋势，不断巩固其作为创新中心和行业交流与合作首要平台的地位。

一系列同期活动打造行业交流的顶级平台。为打造世界级的交流平台并强化其行业引领者的角色，swop 2024 举办了多场由专家主持的论坛和技术交流会。这些活动汇聚了行业领袖、学者和企业代表，全面解读包装行业的最新趋势。

swop 2025 将于 2025 年 11 月 25 日至 27 日在中国上海的上海新国际博览中心 (SNIEC) 举行。

## swop 2024 Concludes with Success

Shanghai World of Packaging (swop) came to a successful close on November 20, 2024 in Shanghai, China, marking a remarkable conclusion to the annual grand show for the packaging industry in Asia. This year's event stood out as a premier annual exhibition, highlighting a fresh vision and a deep alignment with the dynamic needs of the market. With a focus on globalization, swop has firmly established itself as an essential platform for exhibition, communication, and collaboration across the entire packaging value chain.

Covering more than 65,000 square meters, swop 2024 attracted 903 distinguished companies from across the globe, including those from China, Germany, Spain, Finland, the United States, and many other countries and regions. The event drew 33,192 trade visitors from around the world, offering a vibrant space for exhibitors and buyers to engage in fruitful discussions and explore opportunities for collaboration in response to the evolving landscape of global supply chains.

Evian Gu, General Manager of Messe Düsseldorf (Shanghai) Co., Ltd., said: "As an essential bridge connecting production and consumption, the demand for the packaging industry continues to grow. This surge not only highlights the vitality of global trade but also reflects the ongoing drive across industries to innovate and elevate the quality of product packaging. As a member of the interpack alliance, swop benefits from extensive support that boosts its international reach and influence."

Rita Chu, Vice Chairman of The Adsale Group, said, swop has always been a bellwether for industry hotspots and trends, and this year is no exception, delivering an impressive array of highlights. "Sustainability" can be said to be a consensus within the global packaging industry, while "going overseas" represents a new blue ocean for numerous enter-



prises to expand into. This year, swop participants from all walks of life can not only gain insights into the latest dynamics and technological trends in the packaging industry but also find ideal solutions tailored to their own development needs.

### Highlights of swop 2024 – Showcasing Cutting-Edge Packaging Industry Technologies and Development Trends

- Spotlight on digitalization, intelligence, and automation in packaging equipment and new technologies
- Focus on packaging containers and tableware production lines, showcasing innovative technologies and eco-friendly materials
- Leading the green revolution in packaging: Showcasing innovative eco-friendly materials
- FMCG Packaging Pavilion at swop 2024: Empowering brands to shine

The International Pavilion, a stand-out feature of swop 2024, was proudly supported by the "interpack alliance". The event hosted a distinguished ros-

ter of internationally renowned exhibitors. These exhibitors presented cutting-edge packaging solutions from around the globe, demonstrating new quality productive forces driving the international packaging sector. With its strong focus on emerging trends, swop continues to solidify its position as a genuine hub of innovation and a premier platform for industry dialogue and collaboration.

A Series of Concurrent Events Creates a Premier Platform for Industry Exchange. In its pursuit of establishing a world-class communication platform and reinforcing its role as an industry trendsetter, swop 2024 hosted a diverse range of expert-led forums and technology exchange sessions. These events brought together industry leaders, scholars, and corporate representatives to deliver comprehensive insights into the latest trends in packaging.

swop 2025 will be held from November 25 to 27, 2025, at SNIEC (Shanghai New International Expo Centre) in Shanghai, China.

➡ [www.swop-online.com](http://www.swop-online.com)



## 宣布拓展欧洲市场

挤压模具的全球领导者 Guill Tool 最近宣布通过创建 Guill Tool Europe 来扩张欧洲市场。他们将提供全系列的 Guill 产品，以及整个欧洲的销售和工程支持。Padric Lunn 将继续在英国代表 Guill。

从概念设计到工程、制造和支持客户流程，Guill 在常规挤出、多层应

用、护套、多腔、橡胶、硅胶等方面拥有 60 多年的经验。无论何种应用，公司都保持最高的质量标准。

Padraic Lunn Enterprises Ltd 为所有挤出工艺提供全方位的挤出机械和咨询，重点是管材、线材、管材和型材应用。该公司代表英国、爱尔兰和欧洲其他地区的挤出设备公司。

Guill 在每个国家/地区都有当地的销售代表，他期待在欧洲大陆建立强大的影响力。



Gerjan ter Wal , 欧洲销售经理  
*Gerjan ter Wal, Sales Manager, Europe*

## Expansion in the European Market Announced

Guill Tool, global leader in extrusion tooling, recently announced their expansion in the European market with the creation of Guill Tool Europe. They will offer a full line of Guill products, as well as sales and engineering support throughout Europe. Padric Lunn will continue to represent Guill in the UK.

From concept design to engineering, manufacturing and supporting client processes, Guill has more than 60

years of experience in regular extrusion, multi-layered applications, jacketing, multi lumen, rubber, silicone and much more. The company maintains the highest quality standards regardless of application.

Padraic Lunn Enterprises Ltd offers a full range of extrusion machinery and consultancy for all extrusion processes with a strong emphasis on tubing, wire, pipe and profile applications. The firm represents extrusion equipment

companies in the UK, Ireland and other parts of Europe.

With local sales representatives in each country, Guill looks forward to establishing a strong presence on the European continent.

Guill Tool & Engineering Europe  
Gerjan ter Wal, Sales Manager, Europe  
Gerjan.terwal@guill.eu  
www.guill.com

# "ENSŌ" IN MIXING

looking for perfection



in equipment manufacturing for

**PVC DRY-BLEND, MASTER BATCH,  
THERMOPLASTIC RUBBER,  
POWDER COATINGS,  
METALLIC BONDING and WPC**



**plasmec**  
Excellence in Mixing

PLAS MEC S.R.L.  
Via Europa 79, 21015 Lonate Pozzolo (VA) - Italy  
phone +39 0331 301648 - comm@plasmec.it  
www.plasmec.it

## 亚太区新总部位于曼谷

莱芬豪舍在曼谷（泰国）开设了新的亚太区总部。未来，东南亚地区的所有销售、服务和售后市场活动都将从曼谷集中管理。这将使客户能够直接接触到莱芬豪舍的技术组合，获得最佳的现场服务，并通过当地仓库和物流中心更快地获得备件供应。

莱芬豪舍集团在东南亚地区活跃已久，设有多个区域销售和服务部门。新成立的总部扩大并同步了现有的能力。

莱芬豪舍集团首席战略官Marcel Perrevort解释说：“通过新设立的总部，我们专注于该地区的快速市场增长。现在，我们凭借强大的组织力量贴近客

户。在建立长期合作伙伴关系方面，地理位置的接近无可替代。”

莱芬豪舍因此遵循其全球“贴近客户”的战略，以便更好地了解 and 满足市场需求。对本地支持架构的投资能够加快响应速度，并在整个客户服务过程中实现更好的可联系性——从生产线销售到调试、服务以及日常业务中的售后支持。



11月29日，来自亚太总部的莱芬豪舍团队庆祝了其在曼谷的新址开业（图片来源：莱芬豪舍）

The Reifenhäuser team from the Head Office Asia-Pacific celebrated the opening of the new location in Bangkok on November 29 (Picture credit: Reifenhäuser)

## New Head Office Asia-Pacific in Bangkok

Reifenhäuser has opened its new Head Office Asia-Pacific in Bangkok (Thailand). In future, all sales, service and after-market activities for the Southeast Asian region will be managed centrally from Bangkok. This will give customers direct access to

Reifenhäuser's technology portfolio, the best possible on-site service and a faster supply of spare parts via a local warehouse and logistics center.

The Reifenhäuser Group has been active in South-East Asia for a long time – with several regional Sales &

Service Units. The newly established Head Office expands and synchronizes the existing capacities.

Marcel Perrevort, CSO of the Reifenhäuser Group, explains: “With the new establishment, we are focusing on the rapid market growth in this region. We are now close to our customers with a powerful organization. There is no substitute for a close geographical proximity when it comes to building long-term partnerships.”

Reifenhäuser is thus following its global “Close to our customers” strategy in order to better understand and serve market requirements. The investment in local support structures enables faster responses and better accessibility along the entire customer journey - from the sale of a line to commissioning, service and after-sales support in day-to-day business.

Reifenhäuser Group  
www.reifenhäuser.com

## 在印度的地位得到加强

巴斯夫印度有限公司已经在印度Dahaj (达赫杰) 破土动工，以提高其Cellasto®微孔聚氨酯 (MCU) 的生产能力。根据巴斯夫新的“制胜之道”战略，该工厂将采用最先进的技术和自动化系统来建设，以确保巴斯夫的安全和质量高标准得到保持。该工厂预计将于2026年下半年投入运营，在第一阶段将配备新的模具线，并使Cellasto®能够满足快速增长的当地市场的高需求。

Cellasto®致力于“在印度为印度而生产”，于2014年在达赫杰建立了第一家工厂，为汽车行业提供卓越的解决方案，降低噪音、振动和不平顺性。Cellasto®的最新重大投资表明其

准备支持各原始设备制造商的增长计划及其对印度市场的信心。

“新设施是我们创新生产过程努力的一部分。如果需求增加，工厂将灵活地进一步扩大生产。我们强调我们将信守为印度客户服务的长期承诺。我相信，这一战略举措将使我们在印度取得持续的成功，”Cellasto®全球业务管理副总裁Bjoern kopstahl说。

“我们自豪地宣布，我们在印度扩大Cellasto®的产能，以加强我们对这个充满活力的市场的承诺。这条新型模具线将增强我们提供创新的减少振动噪声解决方案的能力，并继续将我们定位为汽车客户的首选合作伙伴。在

巴斯夫，我们仍然专注于提供卓越的质量和量身定制的服务，以满足印度汽车行业的具体需求。这次产能扩张是朝着这个方向迈出的坚定一步，”巴斯夫印度有限公司董事总经理Alexander Gerding说

巴斯夫品牌为Cellasto®，为汽车行业及其供应商开发、制造和销售各种由专门的微孔聚氨酯MCU弹性体制成的组件。自1961年以来，Cellasto®已成为汽车行业领先的全球合作伙伴，共同开发各种应用，如弹簧保险杠、顶级安装座、螺旋弹簧隔离器等。此外，Cellasto®还为工业和消费者应用提供材料解决方案。

## Position in India Strengthened

BASF India Limited has broken ground on a new plant to increase the production capacity of its Cellasto® microcellular polyurethane (MCU) in Dahej, India. Under BASF's new "Winning Ways" strategy, the plant will be constructed with state-of-the-art technologies and automation systems to ensure that BASF's high standards of safety and quality are upheld. The plant, expected to be operational in the second half of 2026, features a new mold line in its first stage and empowers Cellasto® to meet the high demands of the rapidly growing local market.

Committed to "Producing in India for India", Cellasto® established its first plant in Dahej in 2014, providing superior solutions that deliver noise, vibration, and harshness (NVH) reduction to the automotive industry. Cellasto®'s latest significant investment demonstrates its readiness to support the growth plans of various Original Equipment Manufacturers and its confidence in the Indian market.

"The new facility is part of our efforts to innovate the production process. The plant will flexibly expand production further if demand increases. We emphasize our long-term commitment

to better serve our Indian customers. I am confident that this strategic move will position us for sustained success in India," said Bjoern Kophstahl, Vice President, Global Business Management for Cellasto®.

"We are proud to announce the expansion of our Cellasto® production capacity in India as reinforce our commitment to this dynamic market. This new mold line will enhance our ability to deliver innovative NVH reduction solutions and continue to position us as a preferred partner for our automotive customers. At BASF, we remain focused on providing exceptional qual-

# Zumbach

SWISS PRIME MEASURING SINCE 1957



**1-8**

Measurement points



**0.08**

Wall thickness (mm)



**0.2 ... 400**

Object diameter (mm)



**2000+**

Globally installed systems



**up to 8000**

Scan rate (scans/s)

## UMAC®

### Ultrasonic Wall Thickness Measurement Solutions for the Extrusion of Plastic Pipes



#### Benefits:

- ✓ Utilizes ultra-sonic technology to accurately measure wall thickness and concentricity of up to 5 layers simultaneously
- ✓ Measurement of ultra-thin wall thickness down to 0.08 mm and of products with sizes from 0.2 mm to 400 mm
- ✓ Allows for continuous in-line measurements and real-time data acquisition during the extrusion process, ensuring consistent quality control
- ✓ Offers reduced setup times, raw material savings, scrap reduction and fully automated control
- ✓ Over 2000 installed systems, successfully used all over the world



ity and tailored services to meet the specific needs of the automotive industry in India – this capacity expansion is a firm step in that direction," said Alexander Gerding, Managing Director BASF India Limited.

Branded as Cellasto®, BASF develops, manufactures, and sells a di-

verse range of components made from specialized MCU elastomers for the automotive industry and its suppliers. Since 1961, Cellasto® has established itself as a leading global partner to the automotive sector, co-developing various applications such as jounce bumpers, top mounts, coil spring isolators,

and more. Additionally, Cellasto® also offers material solutions for industrial and consumer applications.

► **BASF's Performance Materials division**  
 巴斯夫高性能材料事业部  
[www.performance-materials.basf.com](http://www.performance-materials.basf.com)  
[www.cellasto.com](http://www.cellasto.com)

## 人员信息

布鲁克纳集团是塑料及替代材料加工机械和设备工程领域的市场领导者。其在全球范围内持续取得成功的基础在于具有前瞻性的长期人才战略。这种策略使公司能够始终从其国际组织内部填补空缺的管理职位。

### 一位老员工离职

布鲁克纳机械制造有限公司销售、项目及产品管理部总经理 Helmut Huber ( 赫尔穆特·胡贝尔 ) 于 2024 年底退休。在其 33 年的职业生涯中, Huber 在公司的发展壮大中发挥了关键作用, 曾担任过技术采购员、装配部主管、项目经理、项目管理部主管等职务, 自 2016 年起担任总经理兼首席销售官 ( CSO )。在其任期内, 2021 年创下了销售近 80 条薄膜拉伸生产线的纪录。

### 一位杰出的接班人

自 2025 年 1 月 1 日起, Markus Gschwandtner ( 马库斯·格施万特纳 ) 将接替赫尔穆特·胡贝尔。格施万特纳在薄膜拉伸行业拥有超过 35 年的经验, 曾在中国担任区域销售经理, 后来又担任布鲁克纳机械制造公司东区销售主管。自 2016 年以来, 他作为布鲁克纳服务技术公司的总经理/首席执行官, 展现出了卓越的领导才能, 负责销售和技术工作, 并推动了公司的增长。

### 布鲁克纳服务技术公司的人员更替

Sebastian Lange ( 塞巴斯蒂安·兰格 ) 将于 2025 年 1 月 1 日接替马库斯·格施万特纳。兰格于 2018 年在布鲁克纳集团开启职业生涯, 担任布鲁克纳机械制造公司的高级销售经理。此后, 他调任布鲁克纳集团美国分公



从左至右: 塞巴斯蒂安·兰格 ( 自 2025 年 1 月 1 日起担任布鲁克纳 Servtec 公司的首席执行官 )、阿克塞尔·冯·维德斯佩格博士 ( 布鲁克纳集团首席执行官 )、赫尔穆特·胡贝尔 ( 截至 2024 年 12 月 31 日担任布鲁克纳机械制造公司的首席销售官 )、马库斯·格施万特纳 ( 自 2025 年 1 月 1 日起担任布鲁克纳机械制造公司的首席销售官 )

*From left to right: Sebastian Lange (CEO Brückner Servtec since 01.01. 2025), Dr. Axel von Wiedersperg (CEO Brückner Group), Helmut Huber (CSO Brückner Maschinenbau until 31.12. 2024), Markus Gschwandtner (CSO Brückner Maschinenbau since 01.01. 2025)*

司担任薄膜部门副总裁, 在过去五年里, 他显著地提升了该部门的专业能力, 并增强了布鲁克纳服务技术公司在美国市场的影响力。

布鲁克纳集团首席执行官兼总经理 Dr. Axel von Wiedersperg, ( 阿克塞尔·冯·维德斯佩格博士 ) 对成功的人员

战略发表评论称: “我们很高兴能如此有远见地管理关键职位的接班事宜。马库斯·格施万特纳和塞巴斯蒂安·朗格的任命表明, 长期的职业规划对所有相关人员都有益处。我们领导层所积累的国际经验确保了布鲁克纳集团对卓越的承诺, 这有利于我们的员工、集团以及全球客户。”



## Personalia

The Brückner Group, a market leader in engineering of machinery and equipment for processing plastics and alternative materials. Its continuous global success is based on a forward-thinking, long-term personnel strategy. This approach enables the company to consistently filling open management positions from its own international organisation.

### A Veteran Departs

Helmut Huber, Managing Director of Sales and Project and Product Management at Brückner Maschinenbau GmbH, retired at the end of 2024. Over his 33-year tenure, Huber played a pivotal role in the company's growth, serving in various positions including technical buyer, Head of Assembly, project manager, Head of Project Management, and since 2016, Managing Director and Chief Sales Officer (CSO). His term included the record-breaking year of 2021, with nearly 80 film stretching lines sold.

### An Outstanding Successor

Effective January 1, 2025, Markus Gschwandtner will succeed Helmut Huber. Gschwandtner has over 35 years of experience in the film stretching industry, having excelled as the Regional Sales Manager for China and later as Head of Sales for the Eastern region at Brückner Maschinenbau. Since 2016, he has demonstrated exceptional leadership as Managing Director/CEO of Brückner Servtec, overseeing sales and technology and driving the company's growth.

### Replacement at Brückner Servtec

Sebastian Lange will succeed Markus Gschwandtner as of January 1, 2025. Lange started his career at Brückner Group in 2018 as a Senior Sales Manager at Brückner Maschinenbau. He later moved to Brueckner Group USA as Vice President of the Film Division, where he significantly expanded the division's expertise and strengthened Brückner Servtec's presence in the US market over the past five years.

Dr. Axel von Wiedersperg, Managing Director/CEO of Brückner Group, commented on the successful personnel strategy: "We are delighted to manage the succession of key positions with such foresight. The appointments of Markus Gschwandtner and Sebastian Lange demonstrate that long-term career planning benefits everyone involved. The international experience our leaders have gained ensures Brückner Group's commitment to excellence, benefiting our employees, our Group, and our customers worldwide."

► Brückner Group SE  
www.brueckner.com



## EXPAND YOUR CAPABILITIES

ufi Approved Event **Chinaplas® 2025**  
中国塑料展 2025

Halle 10 - A17

Your competent partner in  
plastics processing mixing,  
dosing, conveying and drying  
Made in Germany

[www.koch-technik.com](http://www.koch-technik.com)



## 泰国的新工厂开业了

ALPLA (阿普拉)正在快速增长的亚太地区扩张,并在泰国开设了第二家工厂。这家现代化的工厂位于曼谷附近的Chachoengsao (北柳府),占地24000平方米,是集所有生产技术、技术中心和设计工作室为一体的一站式设施。因此,这家全球包装及回收专家正在提高产能,扩大其产品组合,并向众多行业及市场提供安全、可承担及可持续发展的塑料全系统解决方案。

阿普拉正在增加其在东南亚的存在。经过一年的建设,这家国际包装和回收专家刚刚在泰国开设了一家现代化工厂。除了生产和管理外,位于曼谷附近北柳府的24,000平方米的新建筑还包括一个产品开发技术中心和亚太地区的第一个工作室,为客户设计新的包装解决方案。阿普拉的第二

个地点在泰国,正在增加其在该国的产能。北柳府的工厂正在取代Prachinburi (巴真府)的工厂作为总部,并扩大其产品组合,包括注塑成型(IM)和一步法注射拉伸吹塑成型(ISBM)技术。

“20多年前,我们在泰国的参与代表了我们在东南亚各项活动的开始,今天仍然是我们增长的核心。Chachoengsao (北柳府)的旗舰工厂涵盖了我们的客户的所有需求,并打开了市场的新机会,” ALPLA首席执行官Philipp Lehner强调。2025年2月11日的开幕式现场约有200名高级嘉宾,包括Pongpol Yodmuangcharoen (工业部部长秘书)、奥地利大使Wilhelm Donko和奥地利联邦经济商会的Michael Friedl。

### 产能增加和投资组合扩张

阿普拉将使用所有核心技术在北柳府生产高质量的塑料瓶、预制件、配套瓶盖和注塑件。其中一个重点是一步法注射拉伸吹塑成型(ISBM)和注射成型(IM),这是两种新引入的技术。“一体化的概念加强了我们的安全、便宜的和可持续发展的塑料包装系统供应商的领先地位。

“北柳府工厂将技术和服务结合在一起。这样,我们希望扩大我们的市场份额,解锁新的细分市场,”阿普拉亚太地区董事总经理Roland Wallner说。北柳府的所有生产线自2025年初开始批量生产。190余名熟练工人受雇于北柳府工厂。曼谷大都会区的新位置因其与客户邻近和最佳连接而脱颖而出。在巴真府的第一家工厂,阿普拉未来将完全专注于挤出模塑(EBM)。

### 高增长的泰国市场

2022年,阿普拉巩固了在东南亚和中国的业务,形成了新的亚太(APAC)业务区。同年,该公司作为泰国公司PTT全球化学的合作伙伴进入回收领域。位于罗永省的联合最先进的回收工厂ENVICCO每年供应3万吨食品级回收PET材料(rPET)和1.5万吨回收HDPE(rHDPE)材料。

在泰国,我们也在与客户一起成长。凭借两个高性能的生产工厂和回收工厂,我们正在确保可持续包装解决方案的长期供应,并加强全国循环经济,”阿普拉泰国总经理Daniel Qiu解释说。阿普拉现在还通过演播室和技术中心为更好的产品提供附加值。客户从开发阶段就参与创新的一站式产品设计商店的活动,并由于轻量化和可回收设计而创造了更可持续的包装。



泰国阿普拉

经过一年的建设,阿普拉将在泰国开设一家新的现代化工厂

*ALPLA\_Thailand: After a year of construction, ALPLA is opening a new, modern plant in Thailand*

## New Plant in Thailand Opened

ALPLA is expanding in the fast-growing Asia-Pacific region and opening a second location in Thailand. The modern plant in Chachoengsao, near Bangkok, combines all production technologies, technical centre and STUDIOa, the one-stop-shop for design, on a 24,000 square metre site. The global packaging and recycling specialist is thus increasing capacities, expanding its portfolio and offer-

ing safe, affordable and sustainable full-system solutions made of plastic to numerous industries and markets.

ALPLA is increasing its presence in Southeast Asia. After a year of construction, the international packaging and recycling specialist has just opened a modern plant in Thailand. In addition to production and administration, the new, 24,000 square metre building in Chachoengsao, near Bangkok, includes a technical centre

for product development and the first STUDIOa in the Asia-Pacific (APAC) region for designing new packaging solutions with customers. With its second location in Thailand, ALPLA is multiplying its production capacity in the country. Chachoengsao is replacing Prachinburi as the headquarters and expanding the portfolio to include injection moulding (IM) and one-step injection stretch-blow moulding (ISBM) technologies.



„Our involvement in Thailand more than 20 years ago represented the start of our activities in Southeast Asia and is still central to our growth today. The flagship plant in Chachoengsao covers all the needs of our customers and unlocks new opportunities in the market,“ emphasises ALPLA CEO Philipp Lehner. The opening on 11 February 2025 saw roughly 200 high-ranking guests on site, including Pongpol Yodmuangcharoen (Secretary to the Minister of Industry), Austrian ambassador Wilhelm Donko and Michael Friedl from the Austrian Federal Economic Chamber.

### Capacity increase and portfolio expansion

ALPLA is going to manufacture high-quality plastic bottles, preforms, matching closures and injection-moulded parts in Chachoengsao using all core technologies. One focus is on one-step injection stretch-blow moulding (ISBM) and injection moulding (IM), which are two newly introduced technologies. „The all-in-one concept strengthens our leading role as a system provider for safe, affordable and sustainable plastic packaging from a single source. Chachoengsao combines technological diversity, the highest quality and customer service under one roof. In this way, we wish to expand our market share and unlock new segments,“ says Roland Wallner, ALPLA Managing Director Region Asia Pacific (APAC).

All production lines have been producing in series since the beginning of 2025. More than 190 skilled workers are employed in Chachoengsao. The



在北柳府阿普拉的剪彩仪式:

阿普拉在北柳府的新工厂开幕 (左起): Issares Charuwonsathid (阿普拉曼谷和业务发展主管)、Wilhelm M. Donko (奥地利大使)、Roland Wallner (阿普拉亚太地区董事总经理)、Pongpol Yodmuangcharoen (工业部长秘书)、Philipp Lehner (阿普拉首席执行官)、Daniel Qiu (阿普拉泰国总经理)、Michael Friedl (奥地利联邦经济商会) 和 Andreas Tabor (阿普拉运营经理) (照片: 阿普拉)

*ALPLA\_Chachoengsao-Ribbon-Cutting:*

*At the opening of the new ALPLA plant in Chachoengsao (from left): Issares Charuwonsathid (ALPLA Head of TC Bangkok & Business Development), Wilhelm M. Donko (Austrian Ambassador), Roland Wallner (ALPLA Managing Director Region Asia Pacific), Pongpol Yodmuangcharoen (Secretary to the Minister of Industry), Philipp Lehner (ALPLA CEO), Daniel Qiu (ALPLA General Manager Thailand), Michael Friedl (Austrian Federal Economic Chamber) and Andreas Tabor (ALPLA Operation Manager) (Photos: ALPLA)*

new location in the Bangkok metropolitan region stands out for its customer proximity and optimal connections. At its first plant in Prachinburi, ALPLA will concentrate fully on extrusion blow moulding (EBM) in the future.

### High-growth Thai market

In 2022, ALPLA consolidated its business in Southeast Asia and China to form the new Asia-Pacific (APAC) region. That same year, the company en-

► Engineered to perform.

## Maximum film performance at full recyclability.

**Full recyclability, excellent transparency and impressive mechanical properties:** Ultra-thin MDO-PE and MDO-PP film produced on SML's latest generation of cast film lines open new opportunities to manufacturers and form the technical basis for the mono-material packaging solutions of tomorrow.



[www.sml.at](http://www.sml.at)

**SML**  
EXTRUSION LINES – ENGINEERED TO PERFORM ►



tered recycling as a joint venture partner of Thai company PTT Global Chemical. The joint state-of-the-art recycling plant ENVICCO in Rayong province supplies 30,000 tonnes of food-grade recycled PET material (rPET) and 15,000 tonnes of recycled HDPE material (rHDPE) annually. „In Thailand, we are also growing together with our custom-

ers. With two high-performance production plants and the recycling plant, we are securing the long-term supply of sustainable packaging solutions and strengthening the nationwide circular economy,“ explains Daniel Qiu, ALPLA General Manager Thailand. ALPLA now also offers added value for better products with STUDIOa as well as the

technical centre. The innovative one-stop-shop for product design includes customers right from the development phase and creates more sustainable packaging thanks to lightweighting and design for recycling.

► ALPLA Group  
www.alpla.com

## 在华扩建，沧州第二条高性能添加剂生产线开工建设



继在河北沧州建立首个添加剂生产基地之后，科莱恩将在该基地扩建第二条生产线，专注于多功能添加剂 Nylostab S-EED 的生产。新设施将由科莱恩及北京天罡的合资公司拥有和运营。

科莱恩聚合物解决方案全球高级副总裁缪志刚表示：“随着沧州工厂第二条生产线的破土动工，我们非常高兴能将科莱恩与天罡的合作关系推向新高度。科莱恩的持续投资不仅展现了我们对中国市场的承诺，也进一步彰显了我们对于纺织和纤维、汽车和包装等本地行业前景的坚定信念。”

自2021年在沧州开设首个合资工厂以来，该厂在过去三年中保持了满负荷运转。沧州生产基地强大的生产力和良好的运营管理为其赢得了良好的声誉，使其成为依托国际背景和专业知识且实力雄厚的本地工厂。新生产线的开工建设有望为当地社区和客户行业带来更大的成功。

科莱恩在华扩建，沧州第二条高性能添加剂生产线开工建设 (© Clariant)

*Clariant begins construction of second high performance additives production line in Cangzhou, China (© Clariant)*

天罡执行董事刘罡先生表示：“天罡非常荣幸能够通过此次扩建，进一步深化与科莱恩的合作。这个生产基地自三年前启动以来，运营一直非常顺利。从合资企业成立之初到第一家工厂的顺利开业运营，我们与科莱恩双方一直配合默契，合作高效。我们希望新生产线能够为本地产业以及我们的中国客户打造更先进的添加剂解决方案。”

于今日开工建设的新生产线将专门生产科莱恩独特的多功能Nylostab S-EED 添加剂。该添加剂通过分子识别技术与尼龙材料高度兼容：在高加工温度下，具有优异的工艺稳定性，可减少纺丝过程中的断丝现象，缩短注塑成型工艺的时间周期提高生产效率。

科莱恩添加剂业务运营和供应链全球总监Sandra Schneider表示：“双方在沧州的首个合资生产基地所取得的成功，毫无疑问为我们今天新产线的建立奠定了基础。我们对新产线生产的新型多功能添加剂 Nylostab S-EED 产品在尼龙核心价值链的各个应用领域中的前景充满信心，尤其是在纺织和工程塑料行业，这些行业在中国正经历着产能扩张和需求激增。”

目前，中国尼龙上游产业扩张迅速。这一增长将刺激对高端添加剂的需求，例如科莱恩的 Nylostab S-EED，该添加剂能够在生产过程中通过增强颜色稳定性、耐热性和复合材料兼容性来提升尼龙制品的质量，全面提高生产效率。



## Construction of Second High Performance Additives Production Line in Cangzhou, China, Begun

Clariant is expanding its Cangzhou production site for the manufacture of the multifunctional additive Nylostab S-EED. The new, second production line in the Hebei Province of China, will jointly be owned and operated by Clariant and its local partner Beijing Tiangang Auxiliary Co., Ltd.

"We are excited to take our partnership with Beijing Tiangang to the next level by breaking ground on a second production line in Cangzhou today. The continued investment from Clariant demonstrates our commitment to the Chinese market and reaffirms our strong belief in the prospects of local industries such as textiles and fibers, automotive and packaging," said Zhigang Miao, Clariant's Global Head of Polymer Solutions, Additives Polymer Solutions.

For three years, since the launch of the first joint-venture site in 2021, the production site has achieved full capacity, earning it an excellent reputation as a strong local facility with established international background and exper-

tise. With construction of the new production line now commencing, success is expected to reach new highs.

"We feel privileged to deepen our partnership with Clariant further through the expansion of this already very successful production site. Since the beginning of our joint venture we have enjoyed wonderful cooperation with Clariant and among our staff. We hope the new production line will offer local industries and our customers in China even more advanced additives solutions," says Gang Liu, Executive Director of Tiangang.

The new production line beginning construction today will specialize in the manufacturing of Clariant's unique multifunctional Nylostab S-EED additive that is highly compatible with nylons by molecular recognition. Its excellent process stability at high temperatures results in less filament breakage during spinning processes and enhances productivity by reducing cycle time for injection molding processes.

"The success of our first joint-venture production site in Cangzhou has undoubtedly paved the way for our new facility today. We're confident that our new multifunctional additive Nylostab S-EED, produced at the new site, will have a good number of application areas across the core nylon value chain, which is seeing a surge in capacity expansion and demand particularly from the textile and engineering plastics industry here in China," says Sandra Schneider, Clariant's Head of Operations & Supply Chain Additives.

The upstream Chinese nylon industry is expanding rapidly, driving an increase in demand for high-end additives such as Nylostab S-EED. This multifunctional additive is capable of upgrading the quality of nylon products through enhanced colour stability, heat resistance and composite compatibility during the manufacturing process, resulting in overall higher productivity.

► Clariant

[www.clariant.com](http://www.clariant.com)

## 推出全新转舌锁设计

挤压模具的全球领导者 Guill Tool 最近宣布在各种十字头上提供其 Cam-Lock 设计。

Cam-Lock 与 Bullet 上提供的相同，并且在适用的情况下将安装在额外的头上。它允许快速轻松地组装和拆卸横梁，并消除了内六角帽螺钉。通过拆卸和更换内部构件，可以在几分钟内而不是几小时挤出不同的型材。由于凸轮锁每次都会以正确的配置重置内部结

构，因此与内六角固定螺钉的组装和错位问题相比，出错的可能性要小得多。凸轮锁提供多种功能，例如：只需转动 1/2 圈即可拆卸和安装导流板尖端，并且不需要紧固硬件。其他功能包括快速更换工具（模具的螺纹固定环和螺纹尖端固定器）、模具从正面拆卸和尖端从背面移除、用于胶质空间调整的工具固定器、真空连接、简化清洁以及减少停机时间和运营成本。



## New Cam- Lock Design Introduced

Guill Tool, the global leader in extrusion tooling, recently announced the availability of its Cam- Lock design on various crossheads. The Cam-Lock is the same as supplied on the Bullet and will be supplied on additional heads, where applicable. It allows quick and easy assembly and disassembly of the crosshead and eliminates the socket head caps screws. By removing and replacing the internals, a different profile can be extruded in minutes rather

than hours. Since the cam lock resets the internals in the right configuration every time, there's far less chance of error, compared to the assembly and misalignment issues with socket set screws. The Cam- Lock offers several features such as: it takes only 1/2 turn to remove and install the deflector tip and no fastening hardware is required. Additional features include fast tool changes (threaded retaining ring for the die and threaded tip retainer), dies

remove from the front and tips from the back, tooling retainers for gum space adjustment, vacuum connections, simplified cleaning and reduced downtime and operating costs.

For more information:

► Guill Tool & Engineering

Tom Baldock, Sales Manager, Extrusion

[tbaldock@guill.com](mailto:tbaldock@guill.com)

[www.guill.com](http://www.guill.com)

## 吹塑模具

挤出模具的全球领导者 Guill Tool 推出其 1000 系列。该系列吹塑挤出模具的芯径在 8.5 英寸 (219.5 毫米) 至 10 英寸 (254.0 毫米) 之间。1025 型使用混合材料, 是医疗、汽车和特种包装的理想选择。

1000 系列可提供单层、共挤或三重挤出。它适应现有的挤出机布局, 在大多数情况下, 接受现有的工具。其特点包括固定中心或可调节的内置筒式加热器、低库存、可扩展到多层、加热芯销、一体式阀体/流量分流器和分流式进料平衡流量。

大多数产品都应该是固定运行的。用户只需更改一个组件即可实现完全可

调。筒式加热器提供均匀的热量, 以获得更好的流动性, 并确保没有任何冷点。低库存不会产生燃烧或停滞, 从而导致快速换色。由于它可以扩展到多层, 因此十字头可以运行各种产品。加热芯销和一体式阀体/流量分流器的优点分别是更好的温度控制和易于清洁/快速更换。最后, 分流进料平衡流在所有速度下都能实现同心壁。

如欲了解更多信息:

▶ Tom Baldock, 挤出业务部销售经理  
tbaldock@guill.com



1000 系列  
Series 1000

## Blow Molding Dies

Guill Tool, the global leader in extrusion tooling, offers its Series 1000. This series of blow molding extrusion dies, features a core diameter between 8.5"

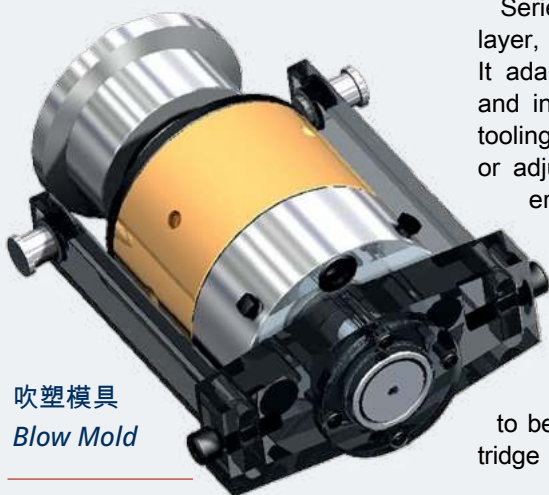

吹塑模具  
Blow Mold

(219.5 mm) – 10" (254.0 mm). Model 1025 uses material blends which are ideal for medical, automotive and specialty packaging.

Series 1000 is available as single layer, co-extrusion or triple extrusion. It adapts to existing extruder layout and in most cases, accepts existing tooling. Features include fixed center or adjustable, built-in cartridge heaters, low inventory, expandable to multi-layer, heated core pin, one-piece body/flow diverter and split feed balanced flow.

Most products should be run fixed. Users need to change only one component to become fully adjustable. The cartridge heaters offer even heat for bet-

ter flow and ensure there aren't any cold spots. Low inventory produces no burning or stagnation, resulting in quick color change. Since it's expandable to multi-layer, the crossheads run a variety of products. Benefits of the heated core pin and one-piece body/flow diverter are better temperature control and easy cleaning/quick change over, respectively. Lastly, the split feed balanced flow achieves concentric walls at all speeds.

For more information:

▶ Guill Tool & Engineering, Co., Inc.  
Tom Baldock, Sales Manager, Extrusion  
tbaldock@guill.com

## 扩张

毛瑟 (Mauser) 包装解决方案公司是全球包装全生命周期解决方案和服务的领导者, 该公司宣布其位于中国海盐的工厂将扩大生产能力。此次战略投资包括用于制造中型散装容器 (IBC) 的先进设备。

新生产线生产的联合国认证的 IBC 适用于化工、食品和添加剂行业, 同时为客户提供全面的 IBC 解决方案组合, 以满足其特定需求此外, 此次投资还支持毛瑟包装解决方案公司 Infinity 系列 IBC 产品线的发展, 该系列采用 Recolene®——一种由空置工业包

装等合适原材料在公司内部制造的高品质再生塑料。这些材料通过公司的 Recover Syst-M 收集系统回收, 并已达到使用寿命的终点。Infinity 系列产品有助于减少浪费、节约原材料并降低温室气体排放。

“我们很自豪能够进一步加强对中国市场和跨国客户的承诺,” 亚太区副总裁兼负责人 Ali Ozbudak 表示。这项投资不仅是为了满足中国市场不断增长的需求, 也是为了推动可持续发展和创新——这些价值观是毛瑟公司包装解决方案的核心所在。

除了中型散装容器 (IBC) 之外, 海盐工厂还生产多种塑料桶。该工厂拥有众多认证, 包括 ISO 9001、14001、22000、HACCP 认证, 最近还获得了 FSSC 22000 认证 (食品安全体系认证), 涵盖中型散装容器和塑料桶的生产。这一全球认可的食品认证体系表明, 该公司已建立起一套符合监管机构、食品制造商及其客户要求的有效食品安全管理体系。该工厂还拥有 10K 级洁净室, 这使得公司能够满足处理敏感或高纯度灌装货物的行业的严格要求。

## Expansion

Mauser Packaging Solutions, a global leader in solutions and services across the lifecycle of packaging, announced the expansion of its capabilities at its Haiyan, China, facility. This strategic investment includes state-of-the-art equipment for the manufacturing of Intermediate Bulk Containers (IBCs).

The new line produces UN-certified IBCs ideal for use in the chemical, food, and additive industries, while offering customers a comprehensive portfolio of IBC solutions to meet their specific needs. Additionally, this investment supports the growth of Mauser Packaging Solutions' Infinity Series IBC line which incorporates Recolene® – high-quality recycled plastic that is manufac-

tured in-house from suitable raw materials, such as empty industrial packaging. These materials have been collected through the company's Recover System and reached the end of their usable life. Infinity Series products help reduce waste, conserve raw materials, and reduce greenhouse gas emissions.

"We are proud to further strengthen our commitment to supporting the Chinese market and multinational customers," said Ali Ozbudak, Vice President, Head of Asia Pacific. "This investment is not only about meeting growing demand on the Chinese market, but also about driving sustainability and innovation – values that are at the core of Mauser Packaging Solutions."

In addition to IBCs, the Haiyan facility also produces multiple types of plastic

drums. It holds numerous certifications such as ISO 9001, 14001, 2200, HAC-CP certification, and recently achieved FSSC 22000 certification (Food Safety System Certification) for IBC and plastic drum production. This globally recognized food safety certification scheme demonstrates that a company has an effective food safety management system in place that meets the requirements of regulators, food manufacturers, and their customers. The facility boasts a 10K grade clean room which enables the company to meet the strict requirements of industries that handle sensitive or high-purity filling goods.

► Mauser Packaging Solutions  
www.mauserpackaging.com

## 推出新型医用级热塑性弹性体 (TPE)

Teknor Apex 作为医疗保健行业定制塑料化合物的可靠供应商，很高兴地宣布公司扩大了医疗级热塑性弹性体 (TPE) 产品组合品类，即新增了专为生物制药管道应用而设计的新等级产品。医疗器械制造商在需要柔韧性或类似橡胶弹性的应用场合

下，会选择热塑性弹性体 (TPE)，因此选择由 Teknor Apex 来提供高质量、符合监管要求且具有可靠性能记录的 Medalist® TPE。

作为一家家族企业，Teknor Apex 在 2024 年迎来了其成立 100 周年的庆典，公司继续秉承创新精神，致力于提供满足医疗保健市场不断演变的需求的解决方案。这些创新的 Medalist® 系列产品专为应对通过滚柱泵连续处理生物制药时所面临的独特挑战而量身定制。

Teknor Apex 的新型 Medalist® TPE 等级提供了引人注目的性能优势组合，包括：

- 增强的透明度：提高了透明度，更便于直观检查流体流动和潜在的颗粒污染。
- 更少的散裂：在长时间泵运行过程中，最大限度减少材料损失和污染风险。
- 更长的泵寿命：增加了管道的耐用性和使用寿命，减少了维护需求和停机时间。



Medalist® MD-90000 系列热塑性弹性体专为解决泵段管道应用中现有产品的散裂问题而设计

*Medalist® MD-90000 Series Thermoplastic Elastomers were uniquely designed to address spallation issues with existing products in pump segment tubing applications*

tems, bioreactors, filtration systems and fluid transfer lines.

► Teknor Apex Gruppe  
www.teknorapex.com

## New Medical Grade Thermoplastic Elastomers (TPEs) Introduced

Teknor Apex announced the expansion of its medical-grade thermoplastic elastomer (TPE) portfolio with new grades specifically designed for biopharmaceutical tubing applications. Medical device manufacturers choose thermoplastic elastomers (TPEs) for applications that require flexibility or rubber-like elasticity. They turn to Teknor Apex to deliver high quality, regulatory-compliant Medalist® TPEs with a proven track record.

Teknor Apex is celebrating its 100th year in 2024. The family-owned company continues to innovate and deliver solutions to meet the evolving needs of the healthcare market. These innovative Medalist® Series are tailored to address the unique challenges asso-

ciated with the continuous processing of biopharmaceuticals through roller pumps.

Teknor Apex's new Medalist® TPE grades offer a compelling combination of performance benefits, including:

- Enhanced Clarity: Improved transparency for visual inspection of fluid flow and potential particle contamination.
- Reduced Spallation: Minimized material loss and contamination risks during extended pump operation.
- Extended Pump Life: Increased durability and longevity of tubing, reducing maintenance requirements and downtime.

These advanced materials are ideal for a wide range of biopharmaceutical applications including single-use sys-





# 挤压技术新发展

## Extrusion Takes Some New Turns

Guill Tool 公司位于美国罗德岛州西沃里克市，多年来一直是医用管材和其他产品挤压模具领域的全球领导者，并在多层共挤模具领域取得了诸多成就。

*A longtime global leader in extrusion tooling for medical tubing and other products, Guill Tool has achieved a series of successes in the areas of multi-layer dies and, most recently, a reciprocal tubing die for wound draining that reconfigures the internal chambers of the tubing to accommodate drainage.*

■最近，该公司又推出了一款往复式伤口引流管模具，此款模具可以重新配置管材的内腔，以适应引流的需要。引流管可用于预防性插入，以防止或清除伤口积液，也可用于治疗性插入，以排出伤口内现有积液。排出积液是为了治疗或预防感染，促进伤口愈合，并提升病人舒适度。引流管还可用于诊断术后并发症，如吻合口瘘或出血。Guill 的模具设计具有独特的功能，无需以焊接等方式连接不同型材的截面。

“我们的自动挤压工艺可在生产中显著改变挤压型材，无需连接内部型材的不同截面。” - Tom Baldock, Guill Tool 销售经理 Guill 设计的这款新型往复式管材模具具有多种独特功能。传统的头端和模具组件由线性往复式组件代替，该组件在给定长度内改变管材的外形。此过程在挤出全程

不间断地重复进行。切割能力外加挤出速度将成品切割成一定的长度。

可降低成本和减少价值流活动，同时提升质量。一次挤压即可产出成品，无需多次挤压、更换模具，以及通过声波焊接等连接方法手工组装不同形状的管材。Guill 的新型往复式挤压头完全消除了装配操作。它还消除了制品库存。因此，无需储存装配、订单履单和成品补给所需的各种形状的管材和接头。

此外，往复式挤压头消除了连接件，允许准时生产和按订单生产产品。最后，它还缩短了从接收订单到发货的总运行时间。

在 Guill Tool 多年来优先关注的多层共挤领域，该公司还推出了最新款 Series 800，这是一款 2 至 6 层挤出模具，旨在生产面向医疗和外科应用的 1/8" 至 6" 外径管材，具有最出色的质量和材料效率。经过重新设计的 Series 800 可



实现含氟聚合物和其他材料的无缝平滑挤出和分层，适用于所有多层、多腔医用管材。Guill 的设计进一步允许聚合物和粘合剂的薄层（0.02 毫米以下）组合。

Guill 提供各种十字头和内联管路模具，具有固定或可调节中心，适用于单挤压或共挤压应用。该模具旨在用于加工所有化合物，具有公司享有专利的精密 Feather Touch 同心度调节器，即 Seal Right 系统，该系统与 Feather Touch 系统相结合，消除了聚合物泄漏。Guill 还提供独特的螺旋流量分配系统。

所有 Guill 模具的生产都利用计算流体动力学 (CFD) 程序进行了严格的流道计算机模拟，从而优化均匀流动，而且没有接合线。

最后，Guill Tool & Engineering Co., Inc. 全新推出的 Series 900 内联管路模具实行标准定价，并提供更好的挤出性能和定制能力。

这个新系列适用于直径从 0.005 英寸（0.127 毫米）到 8.0 英寸（635 毫米）的软管或管材挤出，以及各类聚合物或橡胶 OEM、食品服务、汽车、工业、电信和医疗应用。

Series 900 技术具有以下主要优点：

- 实现同心度或 "产品圆度"，与其他类型的挤出模具相比，可显著降低材料用量
- 无十字线内联设计挤压头不会产生十字线，从而允许更多空气进入，无需可能限制产品产量的冷却支架
- 可同时运行 1-5 层
- 专为多种应用而设计，包括特殊的含氟聚合物应用

Guill Tool Series 900 的一个主要技术亮点是正在申请专利的 FeatherTouch™ 模座调节装置，以及无需松开固定螺钉即可进行调节的筒式滚珠组件。Series 900 的其他独特优势还包括 Guill 的 Seal Right Systems，该系统带来良好

的密封性，可消除导流板之间的泄漏，而且易于自动对准，可减少装配过程中的操作错误，并适应各种特定的挤出机布局配置。

“这个系列提供面向挤压头的标准平台设计，以及针对具体应用的独特功能，且不会增加模具成本。因而，企业能以标准价格获得可定制的精密工具，这是一项卓越优势。这无疑可帮助我们的客户提升利润。”Guill 销售经理 Tom Baldock 表示。

Guill Tool 还使用最先进的计算机数控机床和 EDM 设备制造喷嘴、模具和断流板。此外，该公司还提供工程服务，使用最新的 CAD 系统来定制设计挤压模具产品，如十字头、喷嘴、夹具、法兰、成型辊、无十字网内联模具、模具、摆门、断流板、专用设备和定径模具。

Guill Tool 于 1995 年获得 ISO 认证。作为首家达到国际标准的大型挤出模具公司，Guill Tool 长期以来一直被公认为是定制挤出模具的领先设计商和制造商之一，其产品应用领域包括电线、电缆、光纤、医用管材、木质复合材料、汽车管材、塑料复合、定制应用、橡胶、型材、工业管材、软管/管材、吹塑以及食品和包装等。

Guill Tool 还鼓励并为挤出行业提供教育和培训，包括塑料和铝制模型挤压头、图文并茂的分步组装和拆卸操作手册、培训视频以及挤出模具的维护和清洁课程。

Guill Tool 成立于 1962 年，由 A. Roger Guillemette 在罗德岛创立，最初是为新英格兰地区的电线、电缆或电线电缆、塑料和橡胶行业提供喷嘴、模具、十字头和替换部件的加工厂。后来，Guill Tool 逐步成为整个美国和加拿大的供应商，并迈入全球市场。

医疗领域的技术不断发展，通常需要各种材料和厚度的医疗级管材。Guill 专注于与客户合作设计和制造定制挤压工具，以生产业内最高质量的医用管材。该公司的 Micro Medical 模具可挤出比头发丝更细的管材，每转 0.008 英寸或更细，从而尽可能实现微创手术。其他型号可用于生产喂食用管，包括鼻胃管和空肠管。

各种伤口引流管和手术管设计的内部配置无需再分别挤出和截面连接。Guill 的往复式挤压头设计可连续生产管材内的各种型材。

*Internal configurations of different designs used on wound drain and surgical tubing no longer require separate sections to be extruded, then joined. The Guill reciprocating head design produces various profiles within the tubing in a constant production run*



**D**rain tubes can be inserted prophylactically to prevent or remove the accumulation of fluid in a wound. Alternatively, such tubing can also be therapeutically inserted to evacuate an existing collection of fluid in a wound. Fluid is removed in order to treat or prevent infection and promote wound healing and patient comfort. Drain tubes can also be used to diagnose post-operative complications such as an anastomotic leak or hemorrhage. The Guill design has unique features that eliminate the need to weld or otherwise join sections with different profiles together.

“Our automated extrusion process drastically changes the extruded profile in production, with no need to join separate sections of internal profiles,” comments Tom Baldock, Sales Manager, Guill Tool

Guill has engineered this new reciprocal tubing die with various features, unique to the product. The traditional tip and die assembly is replaced with a linear reciprocating assembly that changes the tube’s profile within a given length. This process is repeated throughout a single extrusion run without interruption. Cutting capability, in association with the extrusion speed, cuts the finished product to length.

While cost and value stream activities are reduced, quality is actually improved. Only one extrusion run is needed to produce a finished product, as opposed to multiple extrusion runs with tooling changes along with a manual assembly operation to connect different tubing shapes via sonic welds or other methods of joining. Guill’s new reciprocating head eliminates this entire assembly operation. It also eliminates in-process inventory. Thus, there is no need for storage of various tubing shapes and connectors needed for assembly, fulfillment of orders and replenishment of finished goods.

Furthermore, the reciprocating head eliminates a connecting piece, allows JIT production and products made-to-order. Lastly, it reduces total run time from receiving the order to shipping product.

In the multi-layer extrusion arena, a primary focus of Guill Tool over the years, the company has also introduced the latest generation of its Series 800, the 2-to-6 layer extrusion tooling designed to produce the highest quality, highest material-efficient 1/8” to 6” OD tubing for medical and surgical applications. The redesigned Series 800 produces flawlessly smooth extrusion and layer definition of Fluoropolymer and other materials for all multi-layer, multi-lumen medical tubing. The Guill design further allows thin layer combinations of polymers and adhesives to .02mm or less.

Guill offers its extensive line of crossheads and inline tubing dies in fixed and adjustable center, for single or co-extrusion applications. The tooling is designed to process all compounds and features the company’s patented, precision Feather Touch Concentricity adjustment, the Seal Right System, which combines with the Feather Touch system to eliminate polymer leaking. Guill also offers its unique spiral flow distribution system.

All Guill tooling is produced with rigorous computer simulation of the flow channels using Computational Fluid Dynamics (CFD) programs, resulting in optimum uniform flow with no weld lines.

Finally, the new Series 900 of inline tubing dies from Guill Tool & Engineering Co., Inc. offers improved extrusion performance and capabilities to customize at standard, off-the-shelf prices.

The new series is applicable to extrusion of hose or pipe ranging from 0.005” (0.127mm) to 8.0” (635mm) in diameter for all types of OEM, food service, automotive, industrial, telecom and medical applications in polymer or rubber.

The Series 900 technology offers these key benefits:

- Achieves concentricity or “product roundness” which greatly reduces material usage compared with other types of extrusion tooling

### Guill Series 800

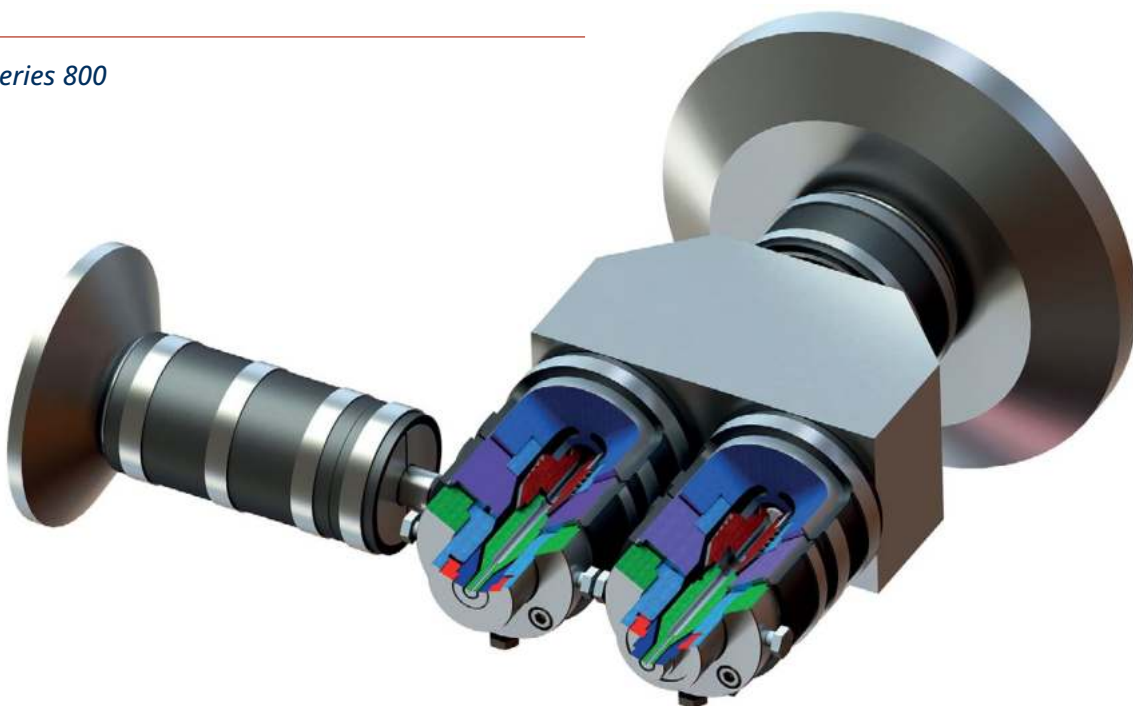



### Guill Series 900



- Spiderless inline-designed heads results in no spider lines and allows room for more air – thus eliminating cold legs, which can inhibit product output
- Runs 1-5 layers simultaneously
- Engineered for a multitude of applications – including special fluoropolymer applications

A key Guill Tool technical highlight of the Series 900 is a patent-pending FeatherTouch™ adjustment in the die holder and a cartridge-style ball assembly that does not require the loosening of retaining screws to make adjustments. Additional unique benefits of the Series 900 include Guill's Seal Right Systems, a positive seal, which eliminates leakage between deflectors, along with easy self-alignment that reduces operator error during assembly and is adaptable to a variety of specific extruder layout configurations.

"This series offers a standard platform design of the head with specific characteristics that are unique to individual applications included at no additional charge in the cost of the tooling. This is a tremendous benefit to a company that requires precision tooling with custom benefits at a standard off-the-shelf price. That certainly helps our customers' bottom line," says Tom Baldock, Guill Sales Manager.

Guill Tool also manufactures tips, dies, and breaker plates using state-of-the-art computerized CNC machining and EDM equipment. As well, engineering services using the latest CAD systems are available for custom-designing extrusion tooling product such as crossheads, tips, clamps, flanges, forming rolls, spiderless inline dies, dies, swing gates, breaker plates, special equipment and sizing dies.

Guill Tool received ISO certification in 1995. The first major extrusion tooling company to meet international standards, Guill Tool has long been recognized as one of the leading established designers and manufacturers of custom extrusion tooling for applications including wire, cable, fiber optics, medical tubing, wood composites, automotive tube, plastic compounding, custom applications, rubber, profile, industrial pipe, hose/tube, blow molding, plus food and packaging.

Guill Tool also encourages and provides education and training for the extrusion industry with plastic and aluminum model heads, fully illustrated operating manuals for step-by-step assembly and disassembly, training videos, and classes on the care and cleaning of extrusion tooling.

Founded in Rhode Island in 1962 by A. Roger Guillemette, Guill Tool was established as a job shop supplying tips, dies, crossheads and replacement parts to the wire, cable or wire and cable, plastic and rubber industries in New England. Later, Guill Tool became a supplier for the entire United States and Canada, and today enjoys a worldwide market presence.

Technology in the Medical field is constantly evolving, and often requires an extensive array of Medical grade tubing in a variety of materials and thicknesses. Guill specializes in working with clients to design and manufacture Custom Extrusion Tooling to produce an unparalleled range of the highest quality Medical tubing in the industry. The company's Micro Medical tooling can extrude tube thinner than a human hair, .008" or finer per revolution, and can be used to keep procedures as non-invasive as possible. Other models are used to produce tubing for feeding applications, including nasogastric and jejunal tubes.

► **Guill Tool & Engineering Co., Inc.**

10 Pike Street, West Warwick, RI 02893, USA  
Tom Baldock, Vertriebsleiter Extrusion, 挤压销售经理  
[www.Guill.com](http://www.Guill.com)

# 将PO管材生产中的能源和原材料成本降至最低

## Minimize Energy and Raw Material Costs in PO Pipe Production

“得益于大家的努力，管材挤出生产线的投资成本很快便得到回报。”巴腾奥茵豪森，德国巴顿菲尔辛辛那提基础设施销售总监，Andreas Türk先生对此深信不疑。完整生产线上各组件不仅彼此完美匹配，而且在技术上的设计与类似系统相比，还可以节省能源和原材料成本。由于生产成本最小化，投资成本仅需三到四年即可摊销。这意味着管材生产厂家在大约15年或更长的管道使用寿命期间节省了资金，并受益于高端产品质量和减少的二氧化碳排放。

*“The investment costs for complete pipe extrusion lines quickly pay off thanks to us,” Andreas Türk, Director Sales Infrastructure at battenfeld-cincinnati GmbH, Bad Oeynhausen, is certain. After all, the components of a complete system are not only perfectly matched to each other but are also technically designed to save both energy and raw material costs compared to similar systems. Thanks to minimized production costs, the investment costs are amortized after just three to four years. This means that the pipe manufacturer saves money during the entire service life of a pipe line of around 15 years or more and benefits from the high end product quality and a reduced CO<sub>2</sub> footprint.*

■ 挤出机不仅是每条管材生产线中最重要的核心部件之一，也是最大的能源消耗部分，在某些情况下占总能耗的80%。Andreas Türk先生强调：“得益于全新solEX NG单螺杆系列挤出机的工艺工程设计，与前几代产品相比，能耗降低了约15%。”这种改进主要是内部机筒，它具有较低的轴向压力分布，并与匹配的螺杆几何形状相结合。这既降低了能耗，又减少了机器磨损。同时，新的加工单元确保在较低10°C左右的温度下具有非常温和以及均匀的熔化性能。

其次，每一条管材生产线上还有不可或缺的核心部件：模具。巴顿菲尔辛辛那提公司的螺旋模具，不仅凭借其独特的专利工艺工程组合——筛篮分配器和螺旋芯棒而获得认可，而且由于其独特的设计，与传统的管材机头相比，其加热能力的能源成本降低了10%。此外，筛篮通过热方式和机械方式使熔体均匀化，从而进一步提高了产品质量。影响管道整体能耗的第三个重要因素是冷却，由真空箱和喷淋水箱组成的下游设备。绿色生产线概念与变频泵和非常高效的供水系统配合使用，两者都有助于降低能源成本。

采用由solEX NG、螺旋模具和绿色生产线下游设备组成的节能完整系统设置，以生产具有SDR 11，产量为1000kg/h的250mm PO管材时，每年可节省约85,000欧元的能源成本，按每年7000小时的产量和每千瓦时12欧元计算。对于传统的能源组合，这相当于315000kg的二氧化碳排量。

与挤出机的能源成本一样，材料消耗是影响生产成本的主要因素：约85%的生产成本归因于所使用的原材料。Andreas Türk先生评论道，“出于生态和经济原因，我们必须确保产生极少的废料，并在最窄的公差范围内生产出最优质产品。”他解释说，来自巴顿菲尔辛辛那提的生产线组件正是为此目的而设计的。由于筛篮分配器和螺旋管头的螺旋心轴的结合，熔体的分布更加精确，这在壁厚较厚的情况下尤为明显。由于熔体质量的提高，管道壁厚的公差范围可以显著减小。除了确保精确计量的重量计量系统和以最小吞吐量波动计量的重量计量系统和以最小吞吐量波动工作的挤出机外，模头内的在线壁厚控制和定心辅助装置也负责精确的壁厚分布和管道的低公差。精确的壁厚分布反过来又最大限度地减少了材料消耗。这里有一个例子：如果带有SDR 33的200 mm PO管的目标壁厚为6.2 mm，在6.22至6.48 mm的窄公差范围内变化，而不是通常的高达7 mm，则以1000 kg/h的生产率每年可以节省约100万欧元的原材料成本，按每公斤/HDPE 1.50欧元和每年7000小时的产量计算。得益于工具的特殊设计，换料时间快，可节约原材料。

在大口径管材生产中，所谓的下垂效应对生产线的经济效益尤为重要。如果能够尽可能地防止这种情况，它将对生产线的效率做出决定性的贡献。近年来，通过管头领域的新发展，这里也取得了相当大的进步。



Andreas Türk总结道：“由于将能源和原材料成本降至最低，我们的管材挤出生产线在经济上非常有吸引力。NG系列的工艺工程设计也提高了产品质量，最大限度地减少了废品和超重。这是一个经济和生态双赢的解决方案。”。

#### 关于巴顿菲尔辛辛那提

巴顿菲尔辛辛那提公司是一家领先的挤出设备制造商，可根据客户的具体要求生产节能高效的挤出机和完整的挤出生产线。

The extruder is not only one of the most important core components in every pipe line, but also the largest energy consumer, accounting for up to 80% of total energy consumption in some cases. “Thanks to the process engineering design of the new solEX NG single-screw series, we have managed to reduce energy consumption by around 15% compared to previous generations,” emphasizes Andreas Türk. The main reason for this improvement is the internally grooved barrel, which has a low axial pressure profile in combination with the matching screw geometry. This leads to both reduced energy consumption and less machine wear. At the same time, the new processing unit ensures a very gentle and homogeneous melting performance at around 10 °C lower temperatures.

The second core component of every pipe line is also indispensable: the helix dies from battenfeld-cincinnati not only score points with the unique and patented process engineering combination of screen basket distributor and spiral mandrel, but due to their design also with 10% lower energy costs for the heating capacity compared to conventional pipe heads. In addition, the screen basket homogenizes the melt thermally and mechanically, which leads to a further improvement in product quality. The third important factor influencing the overall energy consumption of a pipe line is the cooling and therefore the downstream units, consisting of vacuum tanks and spray baths. The green line concept works with frequency-controlled pumps and a very efficient water supply, both of which help to reduce energy costs.

With an energy-efficient complete system set-up consisting of solEX NG, helix die and green line downstream equipment, around EUR 85,000 in energy costs can be saved per year, calculated with 7,000h production p.a. and 12 Euro-

为管材、型材、板片材、热成型和造粒挤出领域的广泛应用，提供量身定制的解决方案，其产品组合包括单螺杆和双螺杆挤出机、模具、下游设备、扩口机和扩口机喂料器。客户由德国、奥地利、中国和美国的生产基地以及全面的全球销售和服务网络提供服务。巴顿菲尔辛辛那提的客户受益于德国、奥地利、中国和美国的生产基地，以及遍布全球销售和服务网络。

cent per kWh, when producing a 250 mm PO pipe with SDR 11 and an output of 1,000 kg/h. With a conventional energy mix, this corresponds to a CO2 equivalent of 315,000 kg.

As with the energy costs of the extruders, material consumption is the main factor influencing production costs: around 85% of production costs are attributable to the raw material used. “For ecological and economic reasons, we have to make sure that little scrap is produced, and that the production of good products is carried out within the narrowest tolerances,” says Andreas Türk, explaining that the line components from battenfeld-cincinnati are designed precisely for this purpose. Thanks to the combination of the screen basket distributor and the spiral mandrel of the helix pipe heads, the melt is distributed more precisely, which is particularly evident with thicker wall thicknesses. Due to the improved melt quality, the tolerance ranges of the wall thicknesses in the pipe can be significantly reduced. In addition to the gravimetric dosing system, which ensures exact quantity dosing, and the extruder, which works with a minimum throughput fluctuation, the inline wall thickness control and the centering aid inside the die head are also responsible for exact wall thickness distributions and low tolerances in the pipe lines. Precise wall thickness distributions in turn minimize material consumption. Here is an example: If the target wall thickness of 6.2 mm of a 200 mm PO pipe with SDR 33 varies within a narrow tolerance range between 6.22 and 6.48 mm instead of the usual up to 7 mm, around 1 million euros in raw material costs can be saved per year at a throughput rate of 1,000 kg/h and calculated with 1.50 Euro per kg/HDPE and 7,000h production p.a. Due to the design of the tools fast color change times support the raw material savings.

*Complete system to produce PO pipes with the solEX extruder, the helix II tooling and the downstream systems vacStream, coolStream, pullStream and cutStream*



使用solEX挤出机、螺旋II模具和下游设备 vacStream、coolStream、pullStream和 cutStream生产PO管材的完整生产线

In large-diameter pipe production, the so-called sagging effect is particularly important for the economic efficiency of a line. If this can be prevented as far as possible, it makes a decisive contribution to the efficiency of the line. Here, too, considerable improvements have been achieved in recent years through new developments in the area of the pipe head.

“Thanks to the combination of minimized energy and raw material costs, our pipe lines are economically very attrac-

tive. The process engineering design of the NG series also increases product quality and minimizes scrap and overweight. A win-win solution, both economically and ecologically,” summarizes Andreas Türk.

► **battenfeld-cincinnati GmbH**

Grüner Weg 9, 32547 Bad Oeynhausen, Germany

[www.battenfeld-cincinnati.com](http://www.battenfeld-cincinnati.com)

# 合作 – 生产包含再生材料的拉伸膜

## Collaboration – Production of Stretch Film that Incorporates Recycled Content

近年来，随着人们对回收的兴趣日益浓厚，人们正在评估各种塑料废物流的可回收潜力。重要的标准是预期的年流量、潜在的污染和溪流物质成分。

*As interest in recycling has grown in importance in recent years, a wide variety of plastic waste streams are being evaluated for their recyclability potential. Important criteria are the expected annual volume, potential contamination and the material composition of the streams.*

■ LDPE/LLDPE 薄膜在许多欧洲国家都有现有的收集系统，这些系统已经存在多年，以提供此类材料进行回收。随着市场在更广泛的应用中需要回收成分，挑战在于生产透明的收缩、拉伸或吹塑薄膜，在保持性能的同时加入回收成分。

在此背景下，欧洲和世界各地都建立了新的产能，或者对现有工厂进行了改造，改进了分拣、清洗步骤或额外的熔体过滤系统，以便能够提供高质量的聚乙烯（rPE）流进行回收。然而，即使是经过大量机械加工的 LDPE/LLDPE 也很难在传统生产线上转化为新薄膜，这就是为什么 Colines、ExxonMobil Signature Polymers 和 Gneuss 公司联手开展一个开发项目，以开发一种可行的薄膜生产工艺，并可能节省成本。

特别是，所谓的凝胶和黑点是破坏性因素，可以通过 ExxonMobil Signature Polymers 的适当材料和 Gneuss 的压力恒定换网器在 Colines 的高柔性流延膜生产线上最大限度地减少。

埃克森美孚特色聚合物的技术专家对从拉伸膜中提取的 PCR 材料（消费后回收）与埃奇得 m 3812 高性能聚乙烯结合使用进行了试验，并观察到较大聚合物凝胶的尺寸减小。

“由于当今欧洲市场上的大多数商业 PCR 等级，挤出生产线通常无法连续运行。连续过滤有助于延长挤出生产线的生产周期。过滤可以去除熔体中存在的大部分杂质，但并非所

有的凝胶，”埃克森美孚技术集团首席挤出客户和应用开发 Bart Lauwers 说。

尽管如此，该项目已经证明了质量和流程的一致性。进行的所有测试都表明，除了与回收物使用无关的常规操作（例如唇模清洁、冷却辊清洁、树脂或格式更改）外，能够始终如一地生产含有 30% PCR 含量的薄膜以供自动使用，一致性为 180-200%，无需停止生产线。

该工艺的一个关键组件是获得专利的 Gneuss RSFgenius 自清洗换网器。这种全自动过滤系统更新了滤网表面，同时没有可测量的压力波动，并且可以适应相关材料，即使在满负荷运行期间，滤网细度通常为 30 - 75µm。

Colines 是一家著名的流延和吹膜生产线制造商，总部位于意大利诺瓦拉。Colines 在满足客户的个性化需求方面表现出非凡的灵活性。不仅完全集成了 Gneuss 换网器，而且还为生产任何类型的胶片提供了完全可定制的生产线设置。

Colines、Gneuss 和 ExxonMobil Signature Polymers 之间的合作已经促成了几条专门用于回收成分掺入的大型生产线的创建，还有更多生产线正在为全球市场开发中。



■ LDPE/LLDPE film has existing collection systems in many European countries that have been in place for many years to provide this type of material for recycling. As markets demand recycled content in a broader range of applications, a challenge is to produce clear shrink, stretch or blown film that maintains properties while incorporating recycled content.

In this context, new capacities have been built in Europe and worldwide or existing plants have been retrofitted with improved sorting, washing steps or additional melt filtration systems in order to be able to offer high-quality polyethylene (rPE) streams for recycling. However, even LDPE/LLDPE that has undergone extensive mechanical processing, can be difficult to convert into new film on conventional production lines, which is why the companies Colines, ExxonMobil Signature Polymers and Gneuss have joined forces in a development project to develop a viable film production process with potential cost savings.

In particular, the so-called gels and black dots are disruptive factors that could be minimized with the appropriate materials from ExxonMobil Signature Polymers and a pressure-constant screen changer from Gneuss on a highly flexible cast film line from Colines.

ExxonMobil Signature Polymers's technical experts have conducted trials using PCR material (Post Consumer Recycle) derived from stretch film in combination with Exceed Tough m 3812 high performance polyethylene and observed a reduction in the size of the larger polymer gels.

**RSFgenius 过滤系统在 Colines 技术中心运行**

*RSFgenius filtration system in operation at Colines' technical center*



**欧洲采用 Gneuss RSFgenius 过滤系统的生产线**

*Production line with Gneuss RSFgenius filtration system in Europe*

With most of the commercial PCR grades available on the European market today, extrusion lines often cannot run continuously. Continuous filtration can help to run extrusion lines for longer production periods. Filtration removes a significant proportion of the impurities present in the melt, but not all the gels," says Bart Lauwers, Principal Extrusion Customer & Application Development at ExxonMobil Technology Group.

Nevertheless, the project has demonstrated quality and process consistency. All tests carried out demonstrated the ability to consistently produce film that incorporated 30% PCR content for automatic use with a consistency of 180 to 200% without the need to stop the line, except for routine operations unrelated to recycle use (e.g. lip die cleaning, chill roll cleaning, resin or format changes).

A key component in this process was the patented Gneuss RSFgenius self-cleaning screen changer. This fully automatic filtration system renewed the screen surface with no measurable pressure fluctuations and can be adapted to the material in question, with screen finenesses typically ranging from 30 - 75µm, even during full operation.

Colines is a renowned manufacturer of cast and blown film lines based in Novara, Italy. Colines has demonstrated exceptional flexibility in meeting the individual needs of its customers. Not only with the full integration of Gneuss screen changers, but also in terms of fully customizable line set-ups for the production of any type of film.

The collaboration between Colines, Gneuss and ExxonMobil Signature Polymers has already led to the creation of several large-scale production lines specifically dedicated to recycled content incorporation with many more in progress for various global markets.

■ **Gneuss Kunststofftechnik GmbH**

Moenichusen 42, 32549 Bad Oeynhausen, Germany

[www.gneuss.com](http://www.gneuss.com)

# 采用回收技术的可持续包装

## Sustainable Packaging with Recycling Technology

Ester Industries 正计划安装 Gneuss OMNI 200 系统，以促进可持续的 BOPET 薄膜生产，符合印度 2025 年的回收目标和监管要求。

*Ester Industries is planning to install Gneuss OMNI 200 system to boost sustainable BOPET film production, aligning with India's 2025 recycling goals and regulatory requirements.*

■ 印度设定了减少塑料垃圾和促进循环经济的目标。到 2025 年，将建立全面的废物收集系统和回收基础设施，以增加包装中回收材料的数量。印度政府正在加强其生产者责任延伸（ERP）法规，特别关注强制性回收配额。公司必须确保其包装中有一定比例由回收材料制成。配额因材料和包装的类型而异，包括后工业和消费后废物。回收配额旨在增加对回收原材料的需求并加强回收物市场。

Ester Industries 是全球领先的聚酯（PET）薄膜制造商，专门生产增值和特种产品。该公司成立于 1985 年，在印度北阿坎德邦的哈蒂马和海得拉巴特伦甘纳邦经营着最先进的制造工厂，并以生产高质量的 BOPET 薄膜而闻名。Ester 服务于全球市场，出口到超过 85 个国家/地区，并提供广泛的产品组合。

Ester Industries 致力于可持续发展，其消费后回收（PCR）PET 薄膜的开发就证明了这一点。该公司继续通过重大投资扩大其业务，例如在印度特伦甘纳邦建立新的生产设施，以提高软包装的生产能力。

为了进一步提高其技术能力，Ester Industries 选择在其新的海得拉巴工厂安装 Gneuss OMNI 200 回收系统，从而能够将瓶片高效加工成食品级颗粒，用于 BOPET 薄膜生产。Gneuss 以其先进的回收技术而闻名，正在提供这种最先进的系统，该系统可处理从印度及周边地区收集的 2,000 公斤/小时的瓶片。这些瓶片直接转化为食品级颗粒，无需预干燥或结晶。OMNI 200 回收系统生产的颗粒将用于 Ester 的 BOPET 薄膜生产线。

OMNI 回收系统由一个 3C 旋转喂料机组成，即使在堆积密度波动的情况下，也能确保挤出机的持续喂料，以实现最大的工艺稳定性。它还包括一个 MRS 挤出机，该挤出机基于传统的单螺杆技术，但包含一个多螺杆脱挥段。这种设计能够对聚合物熔体进行高效、温和的去污，确保材料符合直接食品接触应用的严格标准。用于 Ester Industries 的 OMNI 回收系统使用 MRS 200 挤出机，在 25 mbar 的绝对压力下对熔体进行脱气，从而允许使用坚固的水环泵真空系统。

Ester 新生产车间的 OMNI 200 回收系统的一个独特之处在于双重过滤工艺，可实现低至 16-20  $\mu\text{m}$  的精细过滤。这种质量对于高效加工成 BOPET 薄膜至关重要。它是由两个 RSFgenius 过滤系统实现的，这些系统以最小的材料损失提供最高的过滤质量。这些全自动过滤系统与集成的反冲洗系统一起运行，可在没有过程中断或压力波动的情况下进行自我清洁。

该 OMNI 200 回收系统无需预干燥，可显著减少材料受热的时间，从而实现更温和的加工。另一个关键因素是先进的过滤技术，即使在加工消费后材料时，也能实现精细过滤和极长的筛网寿命。此外，该系统还提供经济和环境效益，包括显著的能源节约和最小的材料损失，使其成为一种高效且可持续的解决方案。

新的 OMNI 回收线预计将于 2025 年中后期投入运营。

India has set a goal to reduce plastic waste and promote a circular economy. Comprehensive waste collection systems and recycling infrastructure will be in place by 2025 to increase the amount of recycled material in packaging. The Indian government is strengthening its Extended Producer Responsibility (ERP) regulations, with a particular focus on mandatory recycling quotas. Companies must ensure that a certain percentage of their packaging is made from recycled material. The quotas vary depending on the type of material and packaging and include both post-industrial and post-consumer waste. The recycling quotas are intended to increase the demand for recycled raw materials and strengthen the market for recyclates.

Ester Industries is a leading global manufacturer of polyester (PET) film, specialising in value-added and specialty products. Established in 1985, the company operates state-of-the-art manufacturing facilities in Khatima, Uttarakhand, and Hyderabad Telangana India, and is known for producing high quality BOPET film. Ester serves a global market with exports to over 85 countries and offers an extensive product portfolio.

Ester Industries is committed to sustainability, as demonstrated by its development of post-consumer recycled (PCR) PET film. The company continues to expand its operations with significant investments such as a new



production facility in Telangana, India, to increase flexible packaging production capacity.

To further enhance its technological capabilities, Ester Industries has chosen to install a Gneuss OMNI 200 recycling system at its new Hyderabad facility, enabling efficient processing of bottle flakes into food-grade pellets for use in BOPET film production. Gneuss, known for its advanced recycling technologies, is supplying this state-of-the-art system that processes 2,000 kg/h of bottle flakes collected from India and the surrounding regions. These bottle flakes are directly converted into food grade pellets without the need for pre-drying or crystallisation. The pellets produced by the OMNI 200 Recycling System will be used in Ester's BOPET film production lines.

The OMNI Recycling System consists of a 3C Rotary Feeder, which ensures constant feeding of the extruder for maximum process stability, even with fluctuating bulk densities. It also includes an MRS extruder, which is based on conventional single-screw technology but incorporates a multi-screw devolatilisation section. This design enables highly efficient and gentle decontamination of the polymer melt, ensuring that the material meets the stringent standards for direct food contact applications. The OMNI Recycling System for Ester Industries uses an MRS 200 extruder that degasses the melt at an absolute pressure of 25 mbar, allowing the use of a robust water ring pump vacuum system.

A unique feature of this OMNI 200 recycling system in Ester's new production hall is the dual filtration process, which allows fine filtration down to 16 to 20 µm. This quality is essential for the efficient processing into BOPET film. It is made possible by two RSFgenius filtration systems that provide maximum filtration quality with minimal material loss. These fully automatic filtration systems operate with integrated backflushing systems, providing self-cleaning without process interruptions or pressure fluctuations.

This OMNI 200 recycling system is without pre drying which significantly reduces the amount of time the material is exposed to heat, allowing for more gentle processing. Another key factor is the advanced filtration technology, which enables fine filtration with exceptionally long screen life, even when processing post-consumer materials. In addition, the system offers both economic and environmental benefits, including significant energy savings and minimal material loss, making it a highly efficient and sustainable solution.

The new OMNI recycling line is expected to be operational by mid to late 2025.

**Gneuss Kunststofftechnik GmbH**

Mönichhusen 42, 32549 Bad Oeynhausen, Germany

[www.gneuss.com](http://www.gneuss.com)

OMNI 200 回收系统，配备 3C 旋转喂料机、MRS 挤出机、水环泵真空系统、双 RSFgenius 换网器和造粒线

*OMNI 200 Recycling System with 3C Rotary Feeder, MRS extruder, water ring pump vacuum system, twin RSFgenius screen changers and pelletising line*





# 全球化思维，本地化行动

## Thinking Globally, Acting Locally

MAAG (马格) 集团总部位于瑞士奥贝格拉特，在国际上运营，一直在加强其在中国的本地化战略。MAAG中国的业务活动和销售不断增加。如今，公司在上海嘉定区的总装厂占地面积7500平方米，最近规模翻了一番。MAAG中国拥有100多名积极进取的员工，为客户提供生产、销售和各種服务。

*The internationally operating MAAG Group, headquartered in Oberglatt, Switzerland, has been stepping up its localization strategy in China. MAAG China has continuously increased its business activities and sales. Today, the company operates in an area of 7500 sqm, the assembly shop at the site in Jiading, a district of Shanghai, has recently doubled in size. MAAG China offers its customers production, sales and various services with over 100 highly motivated employees.*

■ 在瑞士或德国设计的产品，适应中国当地的需求，并在上海工厂生产和组装，节省成本。20多年来，MAAG一直致力于为中国市场实现产品本地化，从零部件到如今复杂的生产系统。MAAG集团总裁Ueli Thürig：“为中国制造”是我们公司近年来一直关注的关键战略之一；在我们上海工厂组装的设备中，90%以上是面向中国市场的。”

MAAG公司已在国内生产GA系列挤出泵、宝力拉条造粒机、朱力水下制粒机。C-USG是M-USG水下切粒系统的类似改造版本，正在扩大特定市场的组合。最初的德国设计构成了这个新版本的基础。虽然一些关键零部件来自德国，但大部分零部件来自当地生产。

为了确保技术复杂的机器能够长期最佳地工作，MAAG中国提供由受过培训的专业人员提供的一流服务，无论产品是在上海MAAG还是在全球任何其他MAAG地点购买的。当地

的仓库都可以储存一些最需要的零部件，可以确保非常快的交货。

在上海（华东）和广州（华南）的本地研磨中心，公司快速、可靠、专业地研磨切割转子、切割刀片和模板，甚至是来自其他制造商的产品。

从最高效的技术咨询，到调试，再到优质的零配件的快速供应和售后服务，MAAG中国提供“出类拔萃”的全方位服务。

**MAAG Group**

[www.maag.com](http://www.maag.com), [www.maag.cn](http://www.maag.cn)

Maag at Chinaplas 2025: Hall 10, Booth D05

Maag at K 2025: Hall 9, Booth A02

中国国际橡塑展2025的Maag: 10号展厅, D05展位

Maag 在 K 2025: 9号展厅, A02展位

Products engineered in Switzerland or Germany, adapted to the local needs in China and – cost savingly – manufactured and assembled in our Shanghai factory. MAAG has been localizing products for the Chinese market for more than 20 years starting from components to nowadays complex production systems. Ueli Thürig, President of the MAAG Group: "‘Made in China for China’ is one of the key strategies our company has been focusing on in recent years; more than 90 percent of the equipment assembled in our Shanghai plant is intended for the Chinese market."

MAAG has already been producing GA series extrusion pumps, BAOLI strand pelletizers, and ZHULI underwater pelletizers in China. The C-USG, a similarly adapted version of the proven M-USG underwater strand pelletizing system is expanding the market-specific portfolio. The original German design forms the basis for this new version. While some key components are supplied from Germany, the majority of parts come from local production.

To ensure that the technically complex machines work optimally over a long term, MAAG China offers top-class services from trained specialist personnel, whether the

*MAAG Group production shop  
in Jiading/Shanghai, China*





MAAG集团在嘉定/上海的员工

MAAG Group employee in Jiading/Shanghai, China

product has been purchased at MAAG Shanghai or any other MAAG location worldwide. A local warehouse to store some most-wanted parts can ensure a very quick delivery.

In the local grinding centers in Shanghai (East China) and Guangzhou (South China) the company grinds cutting rotors, cutting blades and die plates quickly, reliably and professionally – even those from other manufacturers.

Starting with consultancy regarding the most efficient technology, through commissioning through to the quick supply of spare parts in original quality and after-sales service, MAAG China offers an all-round service “par excellence”.

MAAG Group

[www.maag.com](http://www.maag.com), [www.maag.cn](http://www.maag.cn)

Maag at Chinaplas 2025: Hall 10, Booth D05

Maag at K 2025: Hall 9, Booth A02

# MEDIA DATA 2025

MAGAZINE · WEBSITE · NEWSLETTER

# EXTRUSION

EXPERT MEDIA ON PLASTICS EXTRUSION

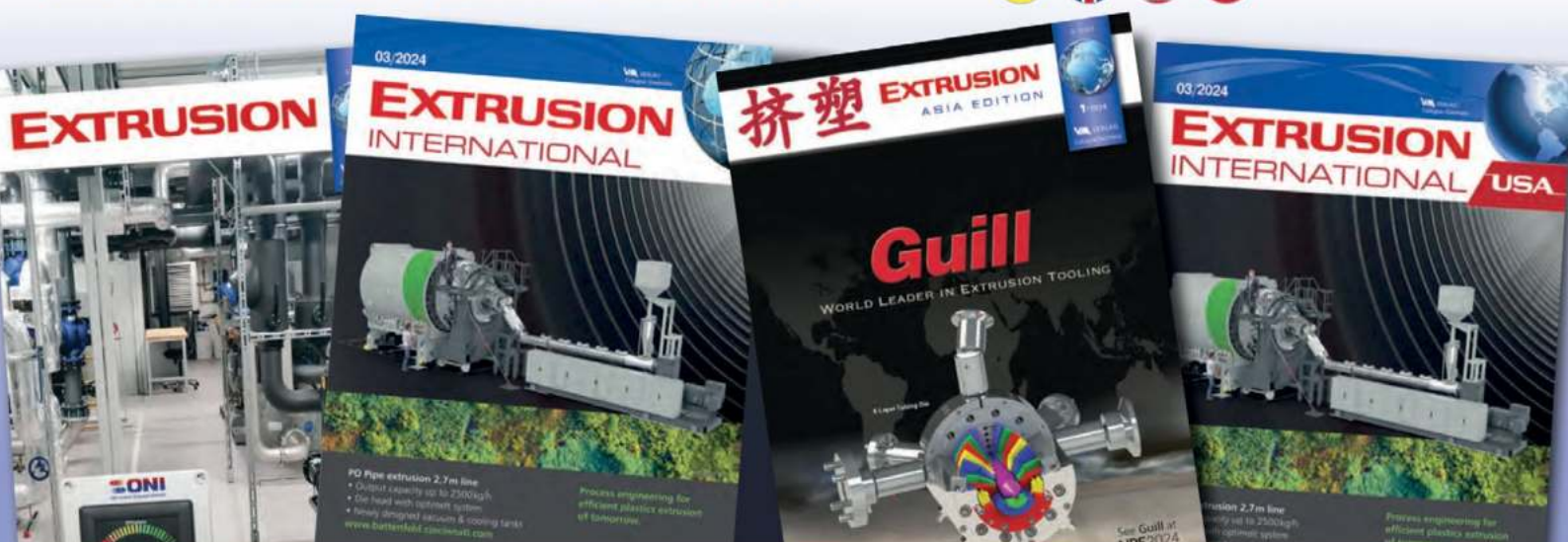



# 数据驱动决策的一站式解决方案

## One-Stop Solution for Data-Driven Decisions

SML是高性能挤出生产线领域的技术领导者之一，进入涂覆和复合设备市场已超过25年。在为其生产线开发数字化服务系统时，SML坚持采用与应用于其他所有核心竞争力相同的“完全自主研发”策略。

*When it comes to high-performance extrusion lines, SML is one of the technological leaders and has been in the market for coating and laminating machines for more than 25 years. When developing digital services for its lines, SML adheres to the same “all in-house”-approach which it applies to all of its other core competencies.*

■ SML的数字化业务事业部团队负责人Christoph Strasser表示：“近年来，‘工业4.0’一直是一个流行词，但根本问题始终在于，使用我们设备的企业如何能从数字化领域取得的快速发展中获益。”与机械工程、电气设计或自动化等所有其他核心竞争力一样，SML严格确保数字化解决方案完全由企业自主开发。位于SML总部不同部门之间的密切合作，支持构建具备完美协同数字化解决方案的连贯挤出概念。



### 数据生成和分析工具Bitwise：分析数据-提高生产率

数据生成与分析工具BitWise是SML数字化业务的核心所在。如今，该工具已应用在全球200多条挤出生产线上。Christoph Strasser继续说：“bitWise能够以极其快速和简便的方式全面采集、处理、分析和传输生产数据。bitWise生成的工艺技术有助于不断优化生产过程和产品质量。”其主要目的是简化工艺流程、识别并解决与质量相关的问题、分析设备故障，最重要的是提高设备生产效率。

最受欢迎的应用领域包括：

- 实时监控各种与工艺或质量相关的生产数据，比如熔体温度、挤出机压力或涂覆重量等，当某些数据偏离时会触发报警功能，
- 数字化班组记录，系统化记录轮班期间的所有事件
- bitWise的跟踪追溯功能：生产过程中生成的所有数据均可对应到特定的成品膜卷，例如通过二维码实现。这为质量控制和产品改进提供了新的契机。

### 为操作员和首席执行官提供灵活的控制面板

bitWise助力实现数据驱动型决策制定，无论对于组织层级中的执行层、规划层还是企业层都适用，它为设备操作人员、维护团队、班组主管、质量经理，尤其是首席执行官和管理层提供支持。为简化日常工作，bitWise的控制面板可按用户的特定工作领域定制。由于bitWise本身是一种基于网络的解决方案，只要公司能够满足系统要求，即可通过平板电脑或个人电脑进行远程访问。





### SML负责bitWise的维护

bitWise由一支技术精湛的团队创建，成员包括七名全栈软件开发人员和数据科学家，他们在自动化和数据分析领域拥有丰富经验，如今仍在进行定期更新。bitWise完全由SML自主开发这一事实带来诸多益处，最重要的是，SML会对其进行全方位维护：

- SML提供自动更新
- SML观察使用的组件并解决安全问题
- SML监控连接到挤出生产线的本地bitWise服务器，在出现问题之前，SML会通知客户。
- 自动添加新功能
- 个性化支持和协助

“For several years now “industry 4.0” has been a popular buzzword but the underlying question is always how the companies that operate our machines can benefit from the rapid developments being accomplished in the digital sector,” Christoph Strasser, Team Leader of SML’s Digital Business Unit, says. Like all of its other core competencies, such as mechanical engineering, electrical design or automation, SML makes sure to keep the development of digital solutions strictly in-house. Close co-operation among the different departments, all located at SML’s headquarters, supports the creation of coherent extrusion concepts with perfectly harmonised digital solutions.

### bitWise: Analysing data – increasing productivity

Bitwise, the data generation and analysis tool, is at the heart of SML’s digital activities. Today it is used in more than 200 extrusion lines around the world. “bitWise enables the comprehensive collection, processing, analysis and transmission of manufacturing data – in an extraordinarily fast and easy manner. The process knowledge bitWise generates, helps to continuously optimise both the manufacturing processes and the product quality,” Christoph Strasser continues. Its main purposes are to streamline workflows, identify and solve problems pertaining to quality, analyse machine defects – and, above all, to increase machine productivity.

The most popular areas of application include

- The real-time monitoring of various process-relevant or quality-relevant production values, such as the melt temperature, extruder pressure or coating weight – with an alarm function, if certain values deviate
- Digital shift books for the systematic documentation of all events during a shift
- The bitWise Track and Trace function: all of the data generated during production can be assigned to a specific, finished film roll, for example via a QR code. This presents new opportunities for quality control and product enhancement.

### Flexible dashboards for operators and CEOs

bitWise enables data-driven decision making, regardless of the organisational level – execution, planning or enterprise. It supports the machine operators, the maintenance team, shift leaders, quality managers and not least the CEO / management. To simplify day-to-day work, the bitWise

### 开放系统-互联互通

bitWise的一个重要特点是其系统开放性：数据交换基于HTML和OPC-UA等开放标准。因此，bitWise为挤出生产线和与之连接的辅助设备（如检测系统、基于云的解决方案或ERP系统）之间的全面数据交换提供完全的互联互通。



dashboard can be customised to suit the specific field of activity of the user. Since bitWise is per se a web-based solution, remote access, i.e. via a tablet or a personal computer is possible, provided that the company can cater to the system requirements.

### SML takes care of bitWise

bitWise was created by a highly skilled team of seven full-stack software developers and data scientists with a wealth of experience in automation and data analytics who now continue to develop it on a regular basis. The fact that bitWise is made 100% at SML generates an array of benefits. Above all, that SML takes care of it in a comprehensive way:

- Automatic updates from SML
- SML observes the components used and closes security issues
- SML monitors the local bitWise server attached to the extrusion lines, customers are notified by SML before problems occur.
- New features can be added automatically
- Personal support and assistance

### Open system – interconnectivity

One vital characteristic of bitWise is its system openness: The data exchange is based on open standards such as HTML and OPC-UA. So bitWise provides full interconnectivity for the comprehensive exchange of data between the extrusion line and connected machine auxiliaries, such as the inspection system, cloud-based solutions or the ERP.

► SML Maschinengesellschaft mbH  
Gewerbepark Ost 32, 4846 Redlham, Austria  
www.sml.at

# 考虑更大：一条现代化的生产大直径管材的生产线

## 聚乙烯管直径高达1600毫米

# Think Big: A Modern Line for the Production of Large-Diameter Polyethylene Pipes up to 1600 mm

特科马蒂克有限公司 ( Tecnomatic ) 宣布向欧洲最著名的管道制造商之一提供其最新的聚乙烯 ( PE ) 管道高产量挤出生产线，专门为直径高达1600毫米的管道设计。这条最先进的生产线汇集了Tecnomatic的尖端ZEUS EVO系列无齿轮挤出机和创新的Venus 1600模头，旨在满足生产大直径厚壁管的需求，具有无与伦比的精度和生产效率。

*Tecnomatic announced the supply of its latest high-capacity extrusion line for polyethylene (PE) pipes, specifically designed for pipes with diameters up to 1600 mm, to one of Europe's most distinguished pipe manufacturers. This state-of-the-art line brings together Tecnomatic's cutting-edge Zeus EVO series gearless extruders and the innovative Venus 1600 die-head, designed to meet the demands of large-diameter, thick-walled pipe production with unparalleled precision and output efficiency.*

■ 这条先进生产线的核心是两台Zeus EVO系列挤出机，旨在提供卓越的动力和效率。更新的螺杆设计提高了物料流的塑化能力，降低了能耗。全新优化的螺旋进料衬套，确保了顺畅一致的进料，减少了波动，提高了均匀性，这是生产均匀壁厚大直径管材的关键因素。挤出机累计产量近2000公斤/小时，高速度已成为生产大直径管道日益苛刻的市场需求所必不可少的。

每台挤出机都配备了一套称重加料系统，具有三个独立的组件，用于超精确加料和重量控制。这种称重测量系统确保了对进料和管道重量的严格控制，可以在每个加料过程中达到特殊的米重精度。精确的计量在保持产品一致性方面发挥着至关重要的作用，特别是在生产大直径管道方面，管壁均匀性是满足质量和性能标准的关键。

### 维纳斯1600模头：先进的定中心为了壁厚一致性

Tecnomatic的生产线采用重新设计的维纳斯1600双螺旋模头，这是生产壁厚均匀的大直径管材的核心。维纳斯1600模头是专门为生产这种大直径的管道设计的，并结合了创新的机械定心和热定心解决方案，即使在生产非常高的壁厚尺寸时也能确保最佳的厚度均匀性。

维纳斯1600的双螺旋设计甚至促进了物料的流动，减少了通常与大管径有关的厚度不一致的风险。定心系统提供了双重的方法：机械调整调节模头的正确定位，而热控制

确保温度在模具内的稳定性。这种组合允许在不同的生产条件下进行精确、实时的调整，以保持管材中心位置和厚度的均匀性。

为了实现大直径管道的高产量，需要一套特殊的冷却和真空系统，Tecnomatic已经解决了超过20米的真空区长度的问题。这种扩展的真空区提供了快速而有效的冷却，对于在高速生产过程中保持管道形状和结构完整性而言至关重要。优化的真空设计有助于生产线在不影响质量的前提下实现品质优异的生产速度。

Tecnomatic的生产线由一家以管道处理系统的质量和精度而闻名的意大利知名制造商配套提供优质的下游设备。下游组件包括一套12履带输送机和一台刀式切割单元，该单元与生产线的输出能力同步工作，确保在整个生产过程中对管道的平稳和精确处理。这种高质量的下游配置最大限度地降低了管材变形的风险，并保持了管道的圆度和干净的切削面光洁度，这对于尺寸精度和表面质量毫无争议的大直径管材应用至关重要。

Tecnomatic先进的PE管材挤出生产线，结合EVO Zeus挤出机与高精度模头和坚固的下游设备，为大直径管材生产提供了全面的、面向未来的解决方案。随着能源效率、材料控制和吞吐量稳定方面的创新，该生产线将重新定义欧洲高性价比、高质量PE管生产的标准。





At the heart of this advanced line are two Zeus EVO series extruders, engineered to deliver outstanding power and efficiency. The updated screw design improves material flow plasticization, and reduces energy consumption. The new optimized spiral feeding bush ensures a smooth and consistent material feed, minimizing fluctuations and enhancing homogeneity, a critical factor for producing large-diameter pipes with uniform wall thickness. Together, the extruders deliver a cumulative output of almost 2,000 kg/h, which enables high-speed, essential for the increasingly demanding market requirements in large-diameter pipe production.

Each extruder is equipped with a gravimetric dosing system featuring three separate components for ultra-precise dosing and weight control. This gravimetric system ensures that material feed and pipe weight are tightly regulated, allowing for exceptional meter weight accuracy across each run. The precision dosing plays a critical role in maintaining product consistency, particularly vital in producing large-diameter pipes, where wall uniformity is key to meeting quality and performance standards.

### Venus 1600 Die-Head: Advanced Centring for Wall Thickness Consistency

The Tecnomatic line includes the re-designed Venus 1600 double-spiral die-head, which is central to producing large-diameter pipes with uniform wall thickness. The Venus 1600 is engineered specifically for pipes of this calibre and integrates innovative mechanical and thermal centring solutions, ensuring optimal thickness uniformity even with very high wall dimensions.

The double-spiral design of the Venus 1600 promotes even material flow, reducing the risk of thickness inconsistencies often associated with large pipe diameters. The centring sys-



tem provides a two-fold approach: mechanical adjustments align the die-head for correct positioning, while thermal control ensures temperature stability within the die. This combination allows for precise, on-the-fly adjustments to maintain pipe centring and thickness uniformity under varying production conditions.

Achieving high output for large-diameter pipes requires an exceptional cooling and vacuum system, which Tecnomatic has addressed with a vacuum length of over 20 meters. This extended vacuum zone provides rapid and effective cooling,





essential for maintaining pipe shape and structural integrity during high-speed production. The optimized vacuum design helps the line achieve superior production rates without compromising on quality.

Tecomatic's line is complemented by premium downstream equipment, supplied by a renowned Italian manufacturer known for quality and precision in pipe handling systems. The downstream components include a 12 caterpillars haul-off and a knife cutting unit that work in sync with the lines' output capacity, ensuring smooth and precise handling of pipes throughout the production process. This high-quality downstream setup minimizes the risk of deformation and maintains the



pipe's roundness and clean cutting finish, crucial for large-diameter applications where dimensional accuracy and surface quality are non-negotiable.

Tecomatic's advanced PE pipe extrusion line, combining the EVO Zeus extruders with a high-precision die-head and robust downstream equipment, provides a comprehensive, future-proof solution for large-diameter pipe production. With innovations in energy efficiency, material control, and throughput stability, this line is set to redefine the standards of cost-effective, high-quality PE pipe production in Europe.

► **Tecomatic Srl**  
Bergamo, Italy  
Tecomaticsril.net

# 节约管道生产的成本

## Cost Savings in the Production of Pipes

“我们研究了机器运转时间、人力成本和废料成本，我们的投资回收期大约是3到4个月。仲巴赫（Zumbach）的Jorge Lage提供的解决方案将我们之前获得准确测量的过程从2小时缩短到5分钟。”SWM国际的生产经理Todd Clarke说。

*“We studied machine time, manpower costs and scrap costs, and the return on our investment was about 3 to 4 months. The solution provided by Jorge Lage at Zumbach reduced our previous process for acquiring an accurate measurement from about 2 hours down to 5 minutes,” Todd Clarke, Production Manager at SWM International.*

■ 总部位于美国费城里奇兰的SWM国际公司是一家专业生产聚丙烯和高密度聚乙烯管的公司。这家公司采用Zumbach electronics（仲巴赫电子）的UMAC®R超声波测量系统，最大限度地提高了其制造效率，同时通过减少废物节省了大量成本。

UMAC®超声波测量系统是一种最先进的解决方案，可以采用无与伦比的精度测量管壁厚度、偏心度和同心度，能够处理的产品直径从0.2mm到400mm。与一系列不同的传感器用户合作开发，使UMAC®有着特别多的功能。集成到UMAC®的是系统级芯片（SoC）单元，称为UMAC®CI。这通过基于菜单的操作扩展了功能（不需要基于回波信号显示的手动设置操作），提供了1kHz的采样频率和集成的web网络服务器。UMAC®R系统提供固定传感器支架，可配置成4,6或8个测量点。环形传感器安装夹具配置为安装到现有的真空罐上，并无缝连接到现有的生产线。

### Zumbach UMAC® R Wall Thickness Visualisation

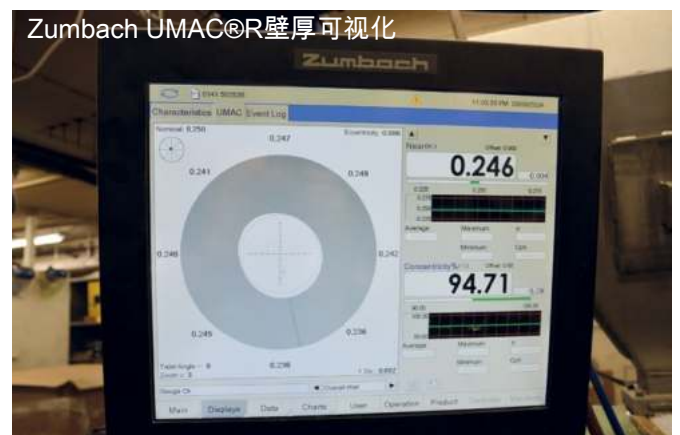

SWM开始了与仲巴赫电子合作的转型之旅，以应对他们在费城Richland的聚丙烯和HDPE管和管道生产设施的关键挑战。传统的卡尺离线测量方法不仅耗时，还会造成大量材料浪费和产生停机时间，推高生产成本，UMAC®R的实施标志着SWM的转折点。该解决方案由仲巴赫电子公司的Jorge Lage提供，提供了快速偏心度测试能力，大大减少了启动时间，并促进了更快的转换。实时反馈使即时调整成为可能，确保了产品质量的一致性，并大大减少了材料浪费。

■ SWM International, based in Richland, Philadelphia, USA, is a specialist in the manufacturing of polypropylene and HDPE tubes and pipes. The company relies on the UMAC® R ultrasonic measuring system from Zumbach Electronic to maximise their manufacturing efficiencies, whilst providing significant cost savings through reduced waste materials.

The UMAC® ultrasonic measuring system is a state-of-the-art solution which measures wall thickness, eccentricity, and concentricity of tubes and pipes with unparalleled precision, with the ability to handle product diameters ranging from 0.2mm up to 400mm. The solution has been developed with a range of different transducer holders that make the UMAC® exceptionally versatile. Integrated into the UMAC® is the System on a Chip (SoC) unit called UMAC® CI. This expands capabilities with recipe-based operation (without requirement of manual setting manipulations based on the echo signal display), provides a 1kHz sample rate and an integrated webserver. The UMAC® R system provides fixed transducer holders, available in configurations for 4, 6 or 8 measuring points. The ring-shaped transducer mounting fixture is configured for installation into an existing vacuum tank and integrates seamlessly into existing production lines.

SWM embarked upon a transformative journey with Zumbach Electronic to address a critical challenge in their polypropylene and HDPE tube and pipe production facility in Richland, Philadelphia. The traditional method of measuring products off-line with calipers was not only time-con-

### SWM国际大直径管道挤出

#### *SWM International's large diameter piping extrusion*



仅在第一年，UMAC®R系统就节省了4万美元的废料，令人印象深刻。SWM国际与仲巴赫电子的合作证明了创新技术如何推动制造过程的显著改善。通过采用UMAC®R测量解决方案，SWM不仅提高了其生产效率，还加强了其对质量和可持续性以及其服务的不同行业的客户满意度的奉献精神。结果是非常显著的。

在一个以精准和效率为关键的世界，SWM 国际战略上采用仲巴赫的UMAC®R，证明了在卓越的运营方实现了创新。



SWM国际公司位于美国宾夕法尼亚州里奇兰生产基地的真空罐

#### *Vacuum Tank at SWM International's Richland, PA production facility*

suming but also resulted in significant material waste and production down-time, driving up production costs, and the implementation of the UMAC® R marked a turning point for SWM. The solution, provided by Jorge Lage at Zumbach Electronic Corp. offered fast eccentricity testing capabilities which significantly reduced start-up times and facilitated quicker changeovers. Real-time feedback enabled immediate adjustments, ensuring consistent product quality and drastically reduced material waste.

In its first year alone, the UMAC® R system delivered an impressive \$40,000 in scrap savings. SWM International's collaboration with Zumbach Electronic exemplifies how innovative technology can drive significant improvements in manufacturing processes. By embracing the UMAC® R measuring solution, SWM has not only enhanced its production efficiency, but also reinforced its dedication to quality and sustainability as well as customer satisfaction across the diverse industries it serves. The results were nothing short of remarkable.

In a world where precision and efficiency are key, SWM International's strategic adoption of Zumbach's UMAC® R stands as a testament to the power of innovation in achieving operational excellence.

► ZUMBACH Electronic AG  
P.O. Box CH-2552 Orpund, Switzerland  
www.zumbach.com





# 通过在挤出、印刷和纸制品加工方面的创新解决方案，实现可持续的软包装

## Sustainable Flexible Packaging through Innovative Solutions in Extrusion, Printing and Converting

CHINAPLAS 2025, ( 中国国际橡塑博览会 ) 将于2025年4月15日至18日在深圳宝安世界会展中心举行。作为全球技术的领导者，W&H通过在挤出、印刷和纸制品加工方面的创新解决方案开发可持续软包装，并将在2025年Chinaplas上展示这些产品。“进入循环”的说法强调了对循环经济和资源保护的承诺。

*CHINAPLAS 2025, a world leading technology-oriented plastics and rubber trade fair, takes place on April 15-18, 2025, in the Shenzhen World Exhibition & Convention Center (Bao'an). As a global technology leader, W&H develops sustainable flexible packaging through innovative solutions in extrusion, printing and converting and will present these at Chinaplas 2025. The claim "get in the loop" emphasizes this commitment to the circular economy and resource conservation.*





■在展位上，W&H将展示挤出、印刷和纸制品加工方面的解决方案，重点是可回收性。其中一项展示将是VAREX的MDO-PE（机器方向单拉伸PE）解决方案，并伴随着来自各种主要行业合作伙伴的样品。此外，W&H将与合作伙伴埃克森美孚合作，展示VAREX的5层吹膜MDO PE，以及OPTIMEX的100% PCR吹膜。FILMEX的PP流延膜和屏蔽结构，包括MDO技术，也将是重点。

此外，W&H将深入研究替代材料，如纸张，以取代传统塑料。无溶剂的柔印和凹印应用，包括阻隔应用，以及多层纸袋的概念，也将进行讨论。其它的主题包括GARANT Maschinen公司的纸袋解决方案，如十字底袋的概念或扁平袋和挎包，旨在提供纸制替代品，如尿布外包装，电子商务邮包。AVENTUS将展示成型-填充-封口（FFS）机器，以及托盘堆垛机和拉伸罩技术。



W&H at Chinaplas 2025:  
Hall 10, Booth G03  
Chinaplas 2025的W&H:  
10号展厅，G03展位

At the booth W&H will display solutions for extrusion, printing and converting with the focus on recyclability. One will be the VAREX's MDO-PE Barrier solutions, accompanied by samples from various key industry partners. Additionally, in collaboration with partner Exxon Mobil, W&H will present VAREX's blown film 5-layer MDO PE, along with OPTIMEX's blown film 100% PCR Collation Shrink. FILMEX's cast film PP and barrier structures, including MDO technology, will also be highlighted.

Furthermore, W&H will delve into alternative materials, such as paper, in place of traditional plastics. Solvent-free flexo- and gravure printing applications, including barrier applications, will be discussed, alongside concepts for Multiwall Paper Sacks.

Other topics to be explored include paper bag solutions by GARANT Maschinen, such as concepts for cross bottom bags or flat and satchel bags, which aim to offer paper alternatives, such as diaper overwraps and e-commerce mailer bags. AVENTUS will be showcasing Form-Fill-and-Seal (FFS) machines, along with palletizers and stretch hooding technology.

Windmüller & Hölscher Group  
www.wuh-group.com

**SIKORA**  
Technology To Perfection

Chinaplas<sup>®</sup> 2025

欢迎莅临  
2025 CHINAPLAS  
我司展位 10J25

### CENTERWAVE 6000 360° 测量大规格管道



- 测量外径在 32 - 1,600 mm 的管材
- 最小壁厚 1.6 mm
- “一键式操作”—— 无需校准，无需预设产品参数
- 对管道进行 360° 测量
- 冷值的动态收缩与熔垂预测

    [www.sikora.net/centerwave6000](http://www.sikora.net/centerwave6000)

# 创新的测量技术与分拣解决方案

## Innovative Measuring Technology and Sorting Solutions

第三十七届中国国际塑料橡胶工业展览（Chinaplas 2025 国际橡塑展）将于 2025 年 4 月 15 - 18 日在深圳举办。SIKORA 将在展会上为您呈现用于软管、管材、管道与塑料行业的高精度测量、控制与分拣设备。来访者不仅可以看到外径测量设备 LASER PRO 系列，还可以在现场与 SIKORA 专家进行充分交流。

*From April 15 to 18, 2025, SIKORA will present highly precise measuring, control and sorting technologies for the hose, tube, pipe and plastics industry in Shenzhen. Visitors can expect, among other things, the new LASER PRO series for diameter measurement as well as an inspiring exchange with experts in a pleasant atmosphere.*

### LASER PRO系列：外径测量的新标准

SIKORA 的 LASER PRO 系列为软管与管材的外径测量树立了新标准。该系列包含三种仪器型号，适用于测量外径在 0.1 - 51 mm 的产品。该系列仪器使用衍射分析法并结合脉冲激光光源对产品进行测量，每秒可得到 10000 次的精确测量结果，确保测量数值既精确又具有重复性。此外，由于曝光时间极短，即便在高线速度产品抖动的情况下也能精准测量，确保每个单一测量值都具有极高的精确度。

### CENTERWAVE 6000：管材与管道的高效在线测量设备

CENTERWAVE 6000 可以非接触式测量外径为 32 - 1600 mm 的管材与管道。该设备可直接安装在生产线上的第一段真空箱后，开机后即可收到管道的测量数值。该设备采用毫米波测量技术，配备连续旋转的收发器与高性能处理系统，对管道的整个圆周进行精确测量。完整且精确的测量数值可确保挤出生产快速调中，减少材料消耗，降低生产成本，并实现可持续化生产。

### PURITY CONCEPT V：塑料颗粒的光学实验室分析

来访者可以携带少量不透明和无定形颗粒、薄片或测试样品压片到 SIKORA 的塑料检测设备展区。在展会期间，我们将使用 PURITY CONCEPT V 检测和分析系统进行杂质检测。该系统适用于实验室的可重复检测应用，能可靠检测到尺寸小至 50  $\mu\text{m}$  的黑色和异色杂质，以及颜色偏差。SIKORA 中国区总经理陈万彬先生介绍：“不到一分钟的时间，即可完成产品的检测分析，并可生成一份详细的检测证书及杂质颜色偏差的 HSV 色谱图表。因此，该系统有助于提升产品质量与安全。”

### X-RAY 6000 PRO：节省生产成本，优化挤出生产线

SIKORA 的 X-RAY 6000 PRO 采用 X 射线检测技术，可以持续提供挤出生产线上软管、管材与管道的壁厚、偏心与内/外径的测量数据。生产数据可以清晰呈现在数据显示处理系统 ECOCONTROL 6000 显示器上。X-RAY 6000 PRO 可安装于挤出机之后，或两个真空箱/冷却水槽之间，也可安装于生产线末端进行冷端测量。从调试之日起，该系统就可以将壁厚控制在最小值范围内，从而为用户节省大量的生产材料与成本。

### SIKORA：将检测技术与展台设计完美融合

SIKORA 在追求技术创新的同时也呈现了极具创意的展台设计。陈万彬先生解释说：“我们不但要为用户提供一流的解决方案，还希望在此次展会为他们打造一个激发创意的环境，以促进彼此的专业交流。”我们诚挚地邀请前来展会的参观者莅临我们的展台，观看并体验我们的创新技术。

### LASER PRO series: New standards in diameter measurement

SIKORA's LASER PRO series sets new standards in diameter measurement of hoses and tubes. The model family includes three devices for product dimensions from 0.1 to 51 mm. By means of diffraction analysis and laser diodes, 10,000 highly precise measuring values (per second) are achieved, which guarantees the highest precision and repeatability. In addition, the short exposure time ensures the highest single value accuracy, even at high line speeds and vibrations of the product.



### CENTERWAVE 6000: Efficient inline measurement of tubes and pipes

The CENTERWAVE 6000 measures non-contact tubes and pipes with diameters from 32 mm to 1,600 mm. The system provides all measured values immediately after the first vacuum tank. Thanks to a continuously rotating transceiver and a powerful processor system, diameter and wall thickness are precisely measured over 360 degrees of the product circumference using millimeter wave technology. This facilitates the centering of extrusion tools, minimizes material consumption, reduces costs and increases sustainability.

### PURITY CONCEPT V: Optical laboratory analysis of plastic pellets

In the "Plastics" area, visitors can bring small quantities of opaque and amorphous pellets, flakes or test sheets. These will be examined for impurities during the show using the PURITY CONCEPT V inspection and analysis system. The system is suitable for reproducible laboratory applications and detects black and colored impurities down to 50 µm in size, as well as discolorations. "The analysis takes less than a minute, including a test certificate and HSV color chart of the detected color deviations. Thus, the system contributes to an increased product and quality safety," says Wanbin Chen, President of SIKORA China.

### X-RAY 6000 PRO: Optimization in extrusion lines through cost savings

With the X-RAY 6000 PRO, SIKORA introduces an innovative system based on X-ray technology that continuously provides measured values for wall thickness, eccentricity

在SIKORA展位，来访者可以详细了解用于产品质量控制的创新型测量设备。

*At the SIKORA booth, visitors can find out about the innovative measuring devices for quality control*



来访者可以在 Chinaplas 现场看到 SIKORA 的 CENTERWAVE 6000，该系统可在挤出过程中精确测量管材和管道的外径与壁厚。

*At Chinaplas, visitors can look forward to seeing the CENTERWAVE 6000, which measures the diameter and wall thickness of pipes and tubes during extrusion*

as well as the inner and outer diameter of hoses, pipes and tubes on extrusion lines. The measuring results are clearly displayed on the monitor of the ECOCONTROL 6000 processor system. The X-RAY 6000 PRO can be used flexibly after the extruder, between two vacuum tanks/cooling sections or at the end of the line for cold measurement. From day one of operation, the system enables precise reduction of the wall thickness to the minimum permissible value – thus ensuring significant material and cost savings.

### SIKORA: Perfection in technology and booth design

SIKORA combines technological innovation with an inviting trade fair presence. "Our goal is not only to offer customers first-class solutions, but also to provide them with an inspiring environment for professional exchange," explains Wanbin Chen. The booth invites visitors to linger and experience the technologies.

➔ SIKORA AG  
Bruchweide 2, 28307 Bremen, Germany  
www.sikora.net

**Sikora at CHINAPLAS 2025:  
Booth 10J25**

# 消费后和工业后回收的创新解决方案

## Innovative Solutions for Post-Consumer and Post-Industrial Recycling

总部位于德国的塑料回收和加工领域的全球领导者 Gneuss 将参加在深圳举行的 2025 年中国国际橡塑展。重点将放在 OMNI 回收系统、旋转过滤系统和 MRS 挤出机上，这些创新技术在塑料加工的效率、可持续性和成本效益方面树立了新标准。

*Gneuss, a global leader in plastics recycling and processing headquartered in Germany, will be exhibiting at Chinaplas 2025 in Shenzhen. The focus will be on OMNI Recycling Systems, Rotary Filtration Systems and MRS Extruders – innovative technologies that set new standards in efficiency, sustainability and cost-effectiveness in plastics processing.*

### OMNI 回收系统：灵活、高效和可持续的循环经济解决方案

对 OMNI 回收系统的需求一直在稳步增长。这主要是因为它们用途广泛，特别适用于消费后和工业后回收。他们将聚酯（PET）、聚苯乙烯（PS）、聚丙烯（PP）和聚乙烯（PE）等各种塑料加工成高质量的最终产品，并在全球范围内使用。

直接接触食品的消费后废物净化是 OMNI 系统的关键应用。典型应用包括

- PET 瓶
- HDPE 瓶盖
- PS 包装
- PP 酸奶罐



格诺斯 OMNImax 回收系统，配备 3C 旋转喂料机、MRS 挤出机和 RSFgenius 过滤系统

*Gneuss OMNImax recycling system with 3C rotary feeder, MRS extruder and RSFgenius filtration system*

Gneuss 技术的净化效率得到了美国食品和药物管理局批准、EFSA 合规性和众多当地批准的证实。

此外，OMNI 回收系统对 PA、SAN 和其他聚合物等材料具有出色的除味和脱气性能，从而显著提高了回收物的质量。

OMNI 回收系统还提供紧凑的设计、系统组件的全自动控制 and 最大的灵活性，以处理波动的进料。

OMNI 系统还可以将挤出过程中产生的能量有效用于下游工艺，从而显著降低能耗、运营成本和碳足迹。

### 具有出色去污性能的 MRS 多螺杆挤出机

MRS 挤出机基于传统的单螺杆技术，配备了独特的多螺杆部分，可实现满足食品接触要求的高效脱气。简单、坚固的真空系统无需预干燥即可将 R-PET 直接加工成高质量的最终产品。获得专利的多螺杆部分带有反向旋转的卫星螺杆，显著增加了聚合物熔体的表面交换，并提供了比其他挤出系统大得多的脱气表面。因此，杂质被彻底去除，回收的颗粒具有优异的光学和机械性能，使其适用于食品应用。

### 创新的过滤技术和易于改造的塑料回收解决方案

在 Chinaplas 国际橡塑展上，格诺斯过滤技术将展示其获得专利的旋转过滤系统。这些连续系统的特点是带有环形分布滤网穴的滤盘。特点：滤网在滤盘不在熔体通道中的一侧进行更换。这使得生产过程可以不间断地进行，即使在高工艺压力和高度变动的消费后污染水平下也是如此。

RSFgenius 过滤器型号还提供自动高压分段冲洗功能，可精确有效地清洁受污染的滤网。滤网表面的各个部分使用确定的最小比例的过滤熔体进行持续清洁，从而将反冲洗损失降至最低。

由于其紧凑的设计，格诺斯过滤系统通常可以很容易地改装到现有的挤出生产线上。他们通过提高效率 and 节省成本，降低材料和运营成本，在短时间内收回成本。

几十年来，格诺斯过滤系统一直在为各种类型聚合物的过滤设定全球标准。



获得专利的 Gneuss 旋转过滤系统，全自动，过程和压力恒定

*Patented Gneuss Rotary Filtration Systems, fully automatic, process- and pressure-constant*



### OMNI Recycling Systems: Flexible, efficient and sustainable solutions for the circular economy

The demand for OMNI recycling systems has been growing at a steady rate. This is not least due to the fact that they are versatile and particularly suitable for post-consumer and post-industrial recycling. They process a wide range of plastics such as polyester (PET), polystyrene (PS), polypropylene (PP) and polyethylene (PE) into high-quality end products and are used worldwide.

Decontamination of post-consumer waste for direct food contact products is a key application for OMNI systems. Typical applications include

- PET bottles
- HDPE bottle caps
- PS packaging
- PP yoghurt pots

The decontamination efficiency of Gneuss technology is confirmed by US Food and Drug Administration approvals, EFSA compliance and numerous local approvals.

In addition, OMNI recycling systems have excellent odour reduction and degassing properties for materials such as PA, SAN and other polymers, which significantly improves the quality of the recyclate.

OMNI recycling systems also offer compact design, fully automatic control of system components and maximum flexibility to handle fluctuating feed materials.

OMNI systems also make efficient use of the energy generated during extrusion for downstream processes, significantly reducing energy consumption, operating costs and carbon footprint.

### MRS multi-screw extruder with outstanding decontamination performance

Based on conventional single-screw technology, the MRS extruder is equipped with a unique multi-screw section for efficient degassing that meets food contact requirements.

A simple, robust vacuum system enables direct processing of R-PET into high quality end products without pre-drying. The patented multi-screw section with counter-rotating satellite screws significantly increases the surface exchange of the polymer melt and provides a degassing surface that is much larger than other extrusion systems. As a result, impurities are thoroughly removed and the recycled pellets have excellent optical and mechanical properties, making them suitable for use in food applications.

### Innovative filtration technologies and easy retrofit solutions for plastics recycling

At Chinaplas, Gneuss Filtration Technology will present its patented Rotary Filtration Systems. These continuous systems are characterised by a filter disc with circular screen cavities. The special feature: The screen is changed on the side of the filter disc that is not in the melt channel. This allows the production process to continue uninterrupted and trouble-free, even at high process pressures and with highly variable post-consumer contamination levels.

The RSFgenius filter model also offers automatic high-pressure segment rinsing, which cleans the contaminated screens precisely and efficiently. The segments of the screen surface are continuously cleaned with a defined, minimal proportion of filtered melt, reducing backflushing losses to a minimum.

Thanks to their compact design, Gneuss filtration systems can usually be easily retrofitted to existing extrusion lines. They pay for themselves in a short time through efficiency and cost savings, reducing material and operating costs.

For decades, Gneuss Filtration Systems have been setting standards worldwide in the filtration of all types of polymers.

► Gneuss Kunststofftechnik GmbH  
Moenichusen 42, 32549 Bad Oeynhausen, Germany  
www.gneuss.com

CHINAPLAS 2025:  
Hall 10 Booth A07 / 10 号馆 A07 展位

# 2025年Chinaplas国际橡塑展我们将展示什么？

## What's up at Chinaplas 2025?

SML近期的研发集中在提升产能、生产效率和设备能效以及提高可回收性以促进循环经济发展方面。

在2025年Chinaplas国际橡塑展上，SML将重点展示高效生产易回收单一材质薄膜的新型多功能流延薄膜生产线，以及生产无菌包装材料的先进TRIPLEX挤出涂覆复合生产线。

In recent months, SML's development efforts have focused on increasing capacity, productivity and efficiency as well as promoting recyclability in the sense of a circular economy.

At Chinaplas 2025, SML will focus on its new type of multi-functional cast film system for the efficient production of easy-to-recycle mono-material film and its advanced TRIPLEX coating and laminating line for aseptic cardboard packaging.

**配置MDO单向拉伸单元的流延薄膜生产线，提供可持续包装解决方案**

除可生产CPP、CPE、流延PET和阻隔膜等标准产品外，SML的新型流延薄膜生产线配备了进一步开发的MDO单元，是专为生产易于回收的单向拉伸薄膜而设计的。

- ▶ 功能多样：产品范围从标准食品和非食品包装到厚度在15 – 60 μm的易回收自立袋薄膜
- ▶ 先进的MDO单元 – 改善薄膜性能
- ▶ 维护简便

**Triplex涂覆复合生产线以一步简单而经济高效的工艺生产无菌包装材料**

SML的Triplex涂覆复合生产线为生产用于乳品或果汁的液体纸板包装材料带来全新方法。该生产线能够以同样的高质量加工薄纸和硬纸板。

- ▶ 优化产品转换 - 减少废料
- ▶ 性价比高
- ▶ 操作舒适，维护简便

SML开发制造的机械设备在可靠性、服役年限和产能质量方面均代表着高标准。

### ▶ **Triplex** 挤出涂覆复合生产线

*TRIPLEX Extrusion coating & laminating line*

#### Cast Film Line with MDO unit for sustainable packaging solutions

Beside standard products, such as CPP, CPE, Cast-PET and barrier films, SML's new cast film line fitted with a further-developed MDO unit is especially designed to process mono-oriented films for easy recycling.

- Wide functional range: standard food and non-food packaging to easy-to-recycle stand-up pouches in a thickness range of 15 to 60 μm
- Advanced MDO unit – improved film properties
- Simple maintenance





**Triplex Coating Lines for aseptic packaging in one simple and cost-effective process**

SML's Triplex coating and laminating lines represent a new approach in the manufacturing of liquid packaging board e.g. for dairy products or fruit juices. It is designed to process thin paper and rigid paperboard at an equally high quality.

- Optimised product change overs -low waste
- Best cost-performance ratio
- Comfortable operation and good accessibility

All machinery developed and manufactured by SML stand for high standards in terms of reliability, longevity and output quality.

► SML Maschinengesellschaft mbH  
 Gewerbepark Ost 32, 4846 Redlham, Austria  
 www.sml.at

**SML at CHINAPLAS 2025:**  
 Hall 10, Booth B43 / 10 号馆 B43 展位

► **CPP/MDO**

流延膜生产线  
 带有集成的 MDO 单元



CPP/MDO Cast film line with integrated MDO-unit

# SMART EXTRUSION

The only website collecting information about smart technologies of extrusion

**38 400 + average monthly visits**

Geographic distribution of Smart\_Extrusion readers, %

- Germany
- Austria and Switzerland
- Italy
- Eastern Europe
- Benelux countries
- Scandinavia

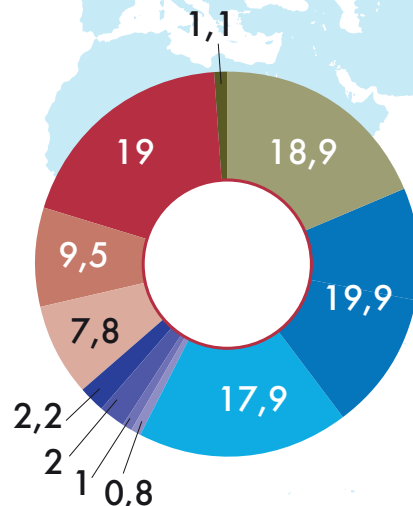

- Other
- Asia
- North America
- South America
- Other Europe

# 高效的拉伸薄膜生产线

## 适用于各种高质量包装和特种薄膜应用的生产线

# Highly Efficient Film Stretching Lines

## Packaging and Specialty Film Lines for a Variety of Top Quality Applications

在深圳举行的 2025 年中国国际橡塑展 ( 10 号馆, J01 展位 ) 上, 布鲁克纳的专注点是为了在生产制造过程中使用最低单位能量和原材料消耗来提供最高效率的拉伸薄膜线。

*At Chinaplas 2025 in Shenzhen (Hall 10, Stand J01) Brückner's clear focus is on the **highest efficiency** of film stretching lines for a manufacturing process with **lowest specific energy and raw material consumption**.*

▶ BOPP 薄膜生产线具有前所未有的 700 米/分钟的生产速度和 10.4 米的幅宽, 适用于广泛的包装应用

▶ BOPET 包装膜生产线的新型轨道系统可实现 650 米/分钟的生产速度, 实现了最高的生产线可用性以及成本效益

▶ 市场上最宽的 BOPA 薄膜生产线: 8.4米宽分步线, 和7.4米同步拉伸线

▶ 全球首创: 8.7米薄膜宽度的电池隔膜生产线概念

▶ 电容薄膜和复合集流体薄膜: 幅宽达 8.4 米的分步和同步拉伸工艺, 用于制造电动汽车的超薄薄膜或用于电力行业可再生能源应用的高能量密度薄膜

○ 薄膜厚度达 2.5或甚至 2 微米 (采用线性电机同步拉伸 LISIM® 技术)

○ 生产线正常运行时间超过 90%

除了这些提高效率的解决方案之外, 布鲁克纳还首次展示了拉伸烘箱 (TDO) 中的排风净化系统:

▶ TDO 烘箱的凝聚物排风采用两级清洁和过滤工艺

▶ 遵守日趋严格的当地和区域环境法规

▶ 可与热回收系统结合使用, 以最大限度地减少对环境的影响

▶ 可改装到现有生产线上

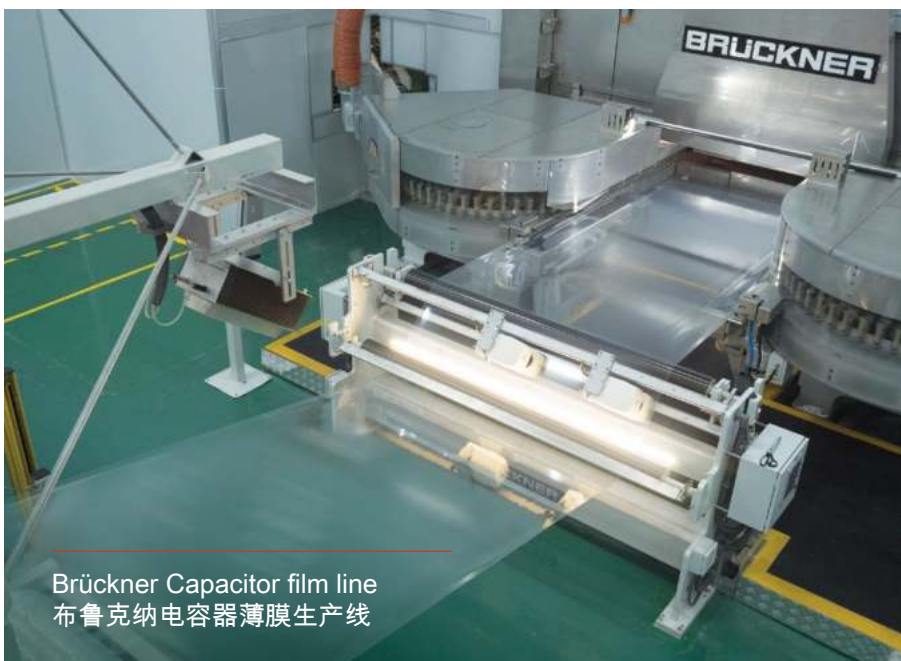

Brückner Capacitor film line  
布鲁克纳电容器薄膜生产线

- BOPP film lines with an unprecedented production speed of 700m/min and a width of 10.4m for a wide range of packaging applications
- New transport system for BOPET packaging film lines for 650m/min production speed, highest line availability as well as cost efficiency
- The market's widest BOPA film production lines: 8.4m for the sequential, 7.4m for the simultaneous technology
- World novelty: Battery separator film line concept with 8.7m film width
- Capacitor films and composite current collector films: Sequential as well as simultaneous stretching process up to 8.4m line width to manufacture extremely thin films for EV applications or high energy density film for renewable energy applications in the power industry
- Film thicknesses down to 2.5 or even 2 micron (with the LISIM® simultaneous technology)
- Line uptimes over 90%

In addition to such efficiency enhancement solutions, Brückner



Brückner BOPA film line  
布鲁克纳 BOPA 薄膜生产线

presents for the very first time an **exhaust air cleaning system** in the stretching oven (TDO):

- Condensate of TDO exhaust air is cleaned and filtered in a two-stage process
- Compliance with increasingly stringent local and regional environmental regulations

• Combination with heat recovery system possible for minimized impact on the environment

- Can be retrofitted to existing lines

Brückner Maschinenbau GmbH,  
Königsberger Str. 5-7,  
83313 Siegsdorf, Germany  
www.brueckner.com

Brückner Maschinenbau at CHINAPLAS 2025:  
Hall 10, Booth J01 / 10 号馆 J01 展位

# 适用于薄膜拉伸生产线的本地化、经济高效且可持续的服务解决方案

## Local, Cost Efficient and Sustainable Service Solutions for Film Stretching Lines

在深圳举办的2025中国国际橡塑展，10号馆 J01展位，布鲁克纳技术服务公司将携手布鲁克纳机械（中国）有限公司，展示本地化服务方案，专业知识与专长，旨在为本地薄膜制造市场提供最优质的服务。

*At Chinaplas 2025 in Shenzhen, hall 10, booth J01, Brückner Servtec together with Brückner Group China present local service solutions, expertise, and specialization in order to best serve the local film manufacturing market.*





*Brückner Servtec — Inline Coating Technology as sustainable upgrade solution*

Brückner Servtec —  
在线涂装技术作为可持续升级解决方案

■秉持“扎根中国，服务中国”的理念，布鲁克纳将借此机会介绍最新的本地化产品，如电气升级，以及位于苏州的布鲁克纳中国的链条与链缺翻新车间扩展的产品组合。展台的其他亮点包括：改进的产线检查流程和可持续的在线涂布技术。

#### 在中国优化的产线检查流程

布鲁克纳中国公司通过精简操作流程，并借助强化培训项目在人员、电气及机械专业知识等关键资源上加大投入，来优化产线检查服务。这种具有前瞻性的举措旨在让中国的生产线检查更加以客户为导向、可靠且经济高效，进而提升整体服务体验。

Following the motto 'In China for China' Brückner will use the opportunity to inform about new localized products such as electrical upgradings as well as the expanded product portfolio of Brückner Group China's Clip and Chain Refurbishment workshop in Suzhou. Other highlights at the booth: improved audit processes and the sustainable inline coating technology.

#### Optimized audit processes in China

Brückner Group China enhances its audit processes by streamlining operations and investing in key resources like personnel, electrical, and mechanical expertise through intensive training programs. This forward-thinking approach aims to make line audits in China more customer-oriented, reliable, and cost-effective, thus improving the overall service experience.

#### 在线涂布技术—可持续的升级解决方案

布鲁克纳技术服务公司将推出先进的在线涂布技术作为产线升级的选项。这是面向包装行业的可持续发展解决方案，通过在BOPP和BOPE薄膜上涂覆薄而均匀的涂层，提高薄膜的可回收性。这项升级不仅提升了回收材料的质量，助力打造更绿色的未来，还赋予薄膜高级的性能，帮助客户开拓未来市场。

“通过拓展本地服务解决方案与能力，我们不仅为客户提高产线运行效率，也进一步表明我们致力于在竞争日益激烈的行业中助力客户实现增长与成功。” Sebastian Lange，布鲁克纳技术服务公司CEO如是说。

#### Inline coating technology as sustainable upgrade solution

Brückner Servtec will introduce the state-of-the art Inline coating technology as an upgrade option, which is a sustainable solution for the packaging industry, by applying thin, uniform coatings to BOPP and BOPE films, enabling higher recyclability. The upgrade not only improves the quality of recycled materials, supporting a greener future but also offers advanced film properties for customers to open up future markets.

“By expanding our local service solutions and capabilities, we are not only enhancing operational efficiency for our customers but also reinforcing our dedication to supporting their growth and success in an increasingly competitive industry,” says Sebastian Lange, CEO of Brückner Servtec.

► Brückner Servtec GmbH,  
Königsberger Str. 5-7, 83313 Siegsdorf, Germany  
www.brueckner-servtec.com

**Brückner Servtec at CHINAPLAS 2025:  
Hall 10, Booth J01 / 10 号馆 J01 展位**

# VACUREMA® 系列每 小时产量高达 6 吨

## VACUREMA® Machines Recycle Up To 6 Tonnes of PET Per Hour

全球对高性能聚酯瓶到瓶回收解决方案的需求正在增加。鉴于这一趋势，对 PET 回收设备覆盖更高产能的要求也在增长。凭借 VACUREMA® 技术，EREMA 提供了一个经过验证的系统，可实现高达每小时 6 吨的产量。

*Demand for high performance solutions for bottle-to-bottle recycling is increasing worldwide. In view of this trend, the specifications for PET recycling machines to handle higher capacities are also growing. With VACUREMA® technology, EREMA offers a proven system that enables throughputs of up to six tonnes per hour.*

“虽然瓶到瓶市场最初是朝着 3 吨每小时的产能的方向发展的，但最近三年来，我们看到对于产量高于 3 吨每小时的系统，其需求在不断增长。”EREMA 瓶部门市场拓展经理 Christoph Wöss 说。“自 2020 年以来，我们在全球安装并调试了十几套产量为每小时 4 至 6 吨的 VACUREMA®。这些大型设备每年总共生产近 350,000 吨再生聚酯粒料，明确体现了这种规模在实践中的存在优势和价值体现。”

### 高产量和最大的灵活性

凭借 VACUREMA® 技术，EREMA 提供了一个成熟的系统，其产量范围为每小时 600 至 6000 公斤。该技术以高效的洁净和柔和的粘度处理而令人信服，并符合欧洲和北美食品安全当局的严格要求。即便是仅仅依靠 Basic 基础版，也能生产出食品级 rPET，无论之后是使用 SSP 装置用于调节粒子粘度做瓶级或其他高粘度等再生产品利用，还是在之前添加真空处理模块实现在线瓶胚生产，或者是之后在线连接其他装置进行在线片材和纤维生产。VACUREMA® 是一款多功能的全能型设备，并且所有产品均为食品级。这种多功能性使运营商能够灵活地应对市场变化和销售波动 - 这是动态市场环境中的一个重要优势，”Wöss 强调说。

### 先进的 VACUNITE® 技术，实现最高的 rPET 质量

对于对 rPET 最终要求特别高的应用，可以选择使用进一步开发的 VACUNITE® 技术。它将久经经验的 VACUREMA® 与氮气环境下集成的真空辅助 SSP 相结合。这种组合进一步优化了材料特性，并显著减少了再生粒料的黄变，这对于瓶到瓶回收的品质是一个关键因素。此外，封闭的氮气循环和优化的过程控制确保了更低的氮气消耗，并最终实现



用于瓶到瓶回收的 VACUREMA® 系统，灵活的技术可实现高达每小时 6 吨的产量，使用基础版就已经能生产出食品级安全的 rPET。

*"The need for high-performance PET recycling systems is growing. More and more customers are specifying large-scale systems with higher throughput capacities to meet the increasing demand for high-quality rPET," says Christoph Wöss, Business Development Manager for the Bottle segment at EREMA ahead of Chinaplas (Photo credits: EREMA GmbH)*

了极其高效和环保的工艺。VACUNITE® 的产量最高可达每小时 2500 公斤，其特点是能耗极其低，设计极其紧凑。

“在一些大国市场，例如拉丁美洲，很明显是朝着更大的 PET 回收工厂发展。我们看到地广人多的中国也有这样的趋势，以满足各类食品级应用下符合不同严格程度的高质

量 rPET 日益增长的需求。” Wöss 告诉我们，“EREMA 已经在中国安装了 50 多套 VACUREMA® 和 VACUNITE® 系统，其中几套每小时产量超过了 4 吨。对于中国的回收商来

说，他们看重 EREMA 系统的多应用支持和灵活性，以及由此获得的全覆盖应用范围和最大销售灵活性。我们期待在展会上与您详细探讨。”

"While the bottle-to-bottle market initially tended towards 3-tonne machines, over the past three years we have been seeing increasing demand for PET recycling solutions with throughputs in excess of three tonnes per hour," says Christoph Wöss, Business Development Manager for the Bottle segment at EREMA. In total, a dozen VACUREMA® ma-

chines with throughput capacities of four to six tonnes have been installed and commissioned worldwide since 2020. "Together, these large recycling machines produce almost 350,000 tonnes of rPET per year, which is a clear sign that this order of magnitude is now commonplace in the industry," adds Christoph Wöss.

### *The highest throughput capacities with maximum flexibility*

With VACUREMA® technology, EREMA offers a proven system for throughputs between 600 and 6000 kilograms per hour. This technology achieves impressively efficient decontamination and gentle IV treatment and fulfils the strict requirements of the European and North American food safety authorities. Even the basic version produces food-grade rPET, providing the basis for a wide range of end applications. Whether the pellets are then used with

SSP for IV adjustment for bottle-to-bottle or high IV applications, an additional upstream vacuum treatment enables direct connection to preform production, or the material is processed inline into sheets or fibres, the VACUREMA® is a versatile all-rounder with food-grade certification. "This versatility allows users to react flexibly to changes in the market and fluctuations in demand, an important advantage in a dynamic market environment," says Christoph Wöss.

### *Advanced VACUNITE® technology for the highest rPET quality*

Applications with especially high material quality requirements are covered by advanced VACUNITE® technology. It combines the proven VACUREMA® system with integrated vacuum-assisted SSP in a nitrogen atmosphere. This combination further optimises the material properties and significantly reduces the yellowing of the pellets, which is an important quality factor in bottle-to-bottle recycling. What is more, the closed nitrogen cycle and optimised process control ensure even lower nitrogen consumption, and ultimately, a particularly efficient and environmentally friendly process. VACUNITE® technology is available on machines for throughputs of up to 2500 kilograms per hour that feature particularly low energy consumption and a compact design.

"In several markets, like Latin America, there is a clear trend towards larger PET recycling machines.

We expect the market to develop this way in China too, to meet the increasing demand for high-quality rPET suitable for sensitive applications such as food packaging," says Christoph Wöss. EREMA has already installed more than 50 VACUREMA® and VACUNITE® systems in China, but only a few with throughputs in excess of four tonnes per hour. Christoph Wöss sees opportunities here: "For Chinese recyclers, the bandwidth and flexibility of the VACUREMA® and VACUNITE® systems offer great potential for a wide variety of applications. We are looking forward to discussing the various options in more detail at Chinaplas."

► EREMA Group  
Unterfeldstr. 3, 4052 Ansfelden, AUSTRIA

**EREMA at Chinaplas 2025: Hall 10, Stand B41**  
**EREMA 展位：10 号展厅，B41 展位**

*VACUREMA® system for bottle-to-bottle recycling: flexible technology that enables throughputs of up to 6 tonnes per hour and produces food-safe rPET even with the basic version*





# EXTRUSION

EXPERT MAGAZINE ON PLASTICS EXTRUSION

The only technical magazine worldwide exclusively for the sectors:

- Material Preparation
- Compounding
- Extrusion
- Recycling
- Calendering
- Thermoforming
- Welding
- Finishing of Plastics and Elastomers



**Extrusion** (German)

**Extrusion International** (English)

**Extrusion International USA** (English)

**Extrusion Asia Edition** (Mandarin/English)

The only plastics trade magazine for Asia, published from Germany

8 issues a year

6 issues a year

6 issues a year

2 issues a year

**SMART  
EXTRUSION**

All editions available for free:

[www.smart-extrusion.com](http://www.smart-extrusion.com)

**VM Verlag GmbH** Cologne/Germany



# SMART EXTRUSION

**THE SPECIALIZED WEBPORTAL  
ON EXTRUSION  
FOR EVERY MODERN NEED**



**VM** Verlag GmbH  
Cologne, Germany



[www.smart-extrusion.com](http://www.smart-extrusion.com)